

DEMOCRATIC SOCIALIST REPUBLIC OF
SRI LANKA



**Supply, Delivery, Installation and Commissioning of Lab Furniture,
Equipment and Other Items for Anatomy Laboratory, Faculty of
Medicine, Uva Wellassa University**

UWU/G/NCB/FOM/23/02

BIDDING DOCUMENT

Bid Opening on	17.10.2023
Bid Validity up to	16.02.2024

Client:

**Uva Wellassa University of Sri Lanka
Passara Road
Badulla**

CONTENTS

Content	Page Nos.
Section I: Instructions to Bidders (ITB)	3-20
Section VI: Conditions of Contract (CC)	21-34
Section VIII: Contract Forms	35-38
Section II: Bidding Data Sheet (BDS)	39-45
Section III: Evaluation and Qualification Criteria	46-47
Section IV: Bidding Forms	48-49
Price Schedule	50-57
Bid Guarantee	58
Manufacture's Authorization	59
Section V: Schedule of Requirements	60-64
Technical specification	65-98
Drawings	99-103
Section VII: Contract Data	104
Procurement Notice	105-106

Section I.
Instructions to Bidders (ITB)

ITB shall be read in conjunction with the Section II, Bidding Data Sheet (BDS), which shall take precedence over ITB. General	
1. Scope of Bid	<p>1.1 The Purchaser indicated in the Bidding Data Sheet (BDS), issues these Bidding Documents for the supply of Goods and Related Services incidental thereto as specified in Section V, Schedule of Requirements. The name and identification number of this procurement are specified in the BDS. The name, identification, and number of package (individual contracts), if any, are provided in the BDS.</p> <p>1.2 Throughout these Bidding Documents :</p> <p>(a) the term “ in writing” means communicated in written form by mail (other than electronic mail) or hand delivered with proof of receipt;</p> <p>(b) if the context so requires “ singular” means “ plural” and vice versa; and</p> <p>(c) “Day” means calendar day.</p>
2. Source of Funds	2.1 Payments under this contract will be financed by the source specified in the BDS.
3. Ethics, Fraud and Corruption	<p>3.1 The attention of the bidders is drawn to the following guidelines of the Procurement Guidelines published by National Procurement Agency:</p> <ul style="list-style-type: none"> • Parties associated with Procurement Actions, namely, suppliers/contractors and officials shall ensure that they maintain strict confidentiality throughout the process; • Officials shall refrain from receiving any personal gain from any Procurement Action. No gifts or inducement shall be accepted. Suppliers/contractors are liable to be disqualified from the bidding process if found offering any gift or inducement which may have an effect of influencing a decision or impairing the objectivity of an official. <p>3.2 The Purchaser requires the bidders, suppliers, contractors, and consultants to observe the highest standard of ethics during the procurement and execution of such contracts. In pursuit of this policy:</p>

	<p>corrupt practice” means the offering, giving, receiving, or soliciting, directly or indirectly, of anything of value to influence the action of a public official in the procurement process or in contract execution;</p> <p>(b) “fraudulent practice” means a misrepresentation or omission of facts in order to influence a procurement process or the execution of a contract;</p> <p>(c) “collusive practice” means a scheme or arrangement between two or more bidders, with or without the knowledge of the Purchaser to establish bid prices at artificial, noncompetitive levels; and</p> <p>(d) “Coercive practice” means harming or threatening to harm, directly or indirectly, persons or their property to influence their participation in the procurement process or affect the execution of a contract.</p> <p>3.3 If the Purchaser found any unethical practices as stipulated under ITB Clause 3.2, the Purchaser will reject a bid, if it is found that a Bidder directly or through an agent, engaged in corrupt, fraudulent, collusive or coercive practices in competing for the Contract in question.</p>
<p>4. Eligible Bidders</p>	<p>4.1 All bidders shall possess legal rights to supply the Goods under this contract.</p> <p>4.2 A Bidder shall not have a conflict of interest. All bidders found to have conflict of interest shall be disqualified. Bidders may be considered to have a conflict of interest with one or more parties in this bidding process, if they:</p> <p>(a) are or have been associated in the past, with a firm or any of its affiliates which have been engaged by the purchaser to provide consulting services for the preparation of the design, specifications, and other documents to be used for the procurement of the goods to be purchased under these Bidding Documents; or</p> <p>(b) Submit more than one bid in this bidding process. However, this does not limit the participation of subcontractors in more than one bid.</p> <p>4.3 A Bidder that is under a declaration of ineligibility by the National Procurement Agency (NPA), at the date of submission of bids or at the date of contract award, shall be disqualified. The list of debarred firms is</p>

	<p>available at the website of NPA, www.npa.gov.lk.</p> <p>4.4 Foreign Bidder may submit a bid only if so stated in the BDS.</p>
5. Eligible Goods and Related Services	<p>5.1 All goods supplied under this contract shall be complied with applicable standards stipulated by the Sri Lanka Standards Institute (SLSI). In the absence of such standards, the Goods supplied shall be complied to other internationally accepted standards.</p>
6. Sections of Bidding Documents	<p>6.1 The Bidding Documents consist of 2 Volumes, which include all the sections indicated below, and should be read in conjunction with any addendum issued in accordance with ITB Clause 8.</p> <p>Volume 1</p> <ul style="list-style-type: none"> • Section I. Instructions to Bidders (ITB) • Section VI. Conditions of Contract (CC) • Section VIII. Contract Forms <p>Volume 2</p> <ul style="list-style-type: none"> • Section II. Bidding Data Sheet (BDS) • Section III. Evaluation and Qualification Criteria • Section IV. Bidding Forms • Section V. Schedule of Requirements • VII. Contract Data • Invitation For Bid <p>6.2 The Bidder is expected to examine all instructions, forms, terms, and specifications in the Bidding Documents. Failure to furnish all information or documentation required by the Bidding Documents may result in the rejection of the bid.</p>
7. Clarification of Bidding Documents	<p>1. A prospective Bidder requiring any clarification of the Bidding Documents including the restrictiveness of specifications shall contact the Purchaser in writing at the Purchaser's address specified in the BDS. The purchaser will respond⁷ in writing to any request for clarification, provided that such request is received no later than ten (10) days prior to the deadline for submission of bids. the purchaser shall forward collies of its response to all those who have purchased the Bidding Documents, including a description of the</p>

	inquiry but without identifying its source. Should the Purchaser deem it necessary to amend the Bidding Documents as a result of a clarification, it shall do so following the procedure under ITB Clause 8.
8.Amendment of Bidding Documents	8.1 At any time prior to the deadline for submission of bids, the Purchaser may amend the Bidding Documents by issuing addendum. 8.2 Any addendum issued shall be part of the Bidding Documents and shall be communicated in writing to all who have purchased the Bidding Documents. 8.3 To give prospective Bidders reasonable time in which to take an addendum into account in preparing their bids, the purchaser may, at its discretion, extend the deadline for the submission of bids, pursuant to ITB Sub-Clause 23.2
9.Cost of Bidding	9.1 The Bidder shall bear all costs associated with the preparation and submission of its bid, and the Purchaser shall not be responsible or liable for those costs, regardless of the conduct or outcome of the bidding process.
10.Language of Bid	10.1 The Bid, as well as all correspondence and documents relating to the Bid (Including supporting documents and printed literature) exchanged by the Bidder and the Purchaser, shall be written in English language
11.Documents Comprising the Bid	11.1 The Bid shall comprise the following: (a) Bid Submission Form and the applicable Price Schedules, in accordance with ITB Clauses 12, 14, and 15; (b) Bid Security or Bid-Securing Declaration, in accordance with ITB Clause 20; (c) documentary evidence in accordance with ITB Clauses 18 and 29, that the Goods and Related Services conform to the Bidding Documents; (d) documentary evidence in accordance with ITB Clause 18 establishing the Bidder's qualifications to perform the contract if its bid is accepted; and (e) Any other document required in the BDS.

<p>12. Bid Submission from and Price schedules</p>	<p>12.1 The Bidder shall submit the Bid Submission Form using the form furnished in Section IV, Bidding Forms. This form must be completed without any alterations to its format, and no substitutes shall be accepted. All blank spaces shall be filled in with the information requested</p>
<p>13. Alternative Bids</p>	<p>13.1 Alternative bids shall not be considered.</p>
<p>14. Bid Prices and Discounts</p>	<p>14.1 The Bidder shall indicate on the Price Schedule the unit prices and total bid prices of the goods it proposes to supply under the Contract.</p> <p>14.2 Any discount offered against any single item in the price schedule shall be included in the unit price of the item. However, a Bidder wishes to offer discount as a lot the bidder may do so by indicating such amounts appropriately.</p> <p>14.3 If so indicated in ITB Sub-Clause 1.1, bids are being invited for individual contracts (package) or for any combination of contracts. Unless otherwise indicated in the BDS, prices quoted shall correspond to 100 % of the items specified for each lot and to 100% of the quantities specified for each item of a lot. Bidders wishing to offer any price reduction (discount) for the award of more than one Contract shall specify the applicable price reduction separately.</p> <p>14.4 (i) Prices indicated on the Price Schedule shall include all duties and sales and other taxes already paid or payable by the Supplier:</p> <ul style="list-style-type: none"> (a) on components and raw material used in the manufacture or assembly of goods quoted; or (b) on the previously imported goods of foreign origin <p>(ii) However, VAT shall not be included in the price but shall be indicated separately;</p> <p>(iii) the price for inland transportation, insurance and other related services to deliver the goods to their final destination;</p> <p>(iv) the price of other incidental services</p> <p>14.5 The Prices quoted by the Bidder shall be fixed during the Bidder's performance of the Contract and not subject to variation on any account. A bid submitted with an adjustable price quotation will be treated as non-</p>

	<p>responsive and rejected, pursuant to ITB Clause 31.</p> <p>14.6 All package, if any and items must be listed and priced separately in the Price Schedules. If a Price Schedule shows items listed but not priced, their prices shall be assumed to be included in the prices of other items</p>
15.Currencies of Bid	<p>15.1 Unless otherwise stated in Bidding Data Sheet, the Bidder shall quote in Sri Lankan Rupees and payment shall be payable only in Sri Lanka Rupees.</p>
16. Documents Establishing the Eligibility of the Bidder	<p>16.1 To establish their eligibility in accordance with ITB Clause 4, Bidders shall complete the Bid Submission Form, included in Section IV, Bidding Forms.</p>
17. Documents Establishments	<p>17.1 To establish the conformity of the Goods and Related Services to the Bidding Documents, the Bidder shall furnish as part of its Bid the documentary evidence that the Goods conform to the technical specifications and standards specified in Section V, Schedule of Requirements.</p> <p>17.2 The documentary evidence may be in the form of literature, drawings or data, and shall consist of a detailed item by item description (given in Section V, Technical Specifications) of the essential technical and performance characteristics of the Goods and Related Services, demonstrating substantial responsiveness of the Goods and Related Services to the technical specification, and if applicable, a statement of deviations and exceptions to the provisions of the Schedule of Requirements.</p> <p>17.3 The Bidder shall also furnish a list giving full particulars, including quantities, available sources and current prices of spare parts, special tools, etc., necessary for the proper and continuing functioning of the Goods during the period if specified in the BDS following commencement of the use of the goods by the Purchaser.</p>

<p>18.Documents Establishing the Qualifications of the Bidder</p>	<p>18.1 The documentary evidence of contract if its bid is accepted shall establish</p> <p>(a) A Bidder that does not manufacture or produce the Goods it offers to supply shall submit the Manufacturer’s Authorization using the form included in section IV, Bidding Forms to demonstrate that it has been duly authorized by the manufacturer or producer of the Goods to supply these Goods;</p> <p>(b) that, if required in the BDS, in case of a Bidder not doing business within Sri Lanka, the Bidder is or will be (if awarded the contract) represented by an Agent in Sri Lanka equipped and able to carry out the Supplier’s maintenance , repair and spare parts stocking obligations prescribed in the Conditions of Contract and/or Technical Specifications; and</p> <p>(c) That the Bidder meets each of the qualification criteria specified in Section III, Evaluation and Qualification Criteria</p>
<p>19.Period of Validity of Bids</p>	<p>19.1 Bids shall remain valid until the date specified in the BDS. A bid valid for a shorter date shall be rejected by the Purchaser as non-responsive.</p> <p>19.2 In exceptional circumstances, prior to the expiration of the bid validity date, the Purchaser may request bidders to extend the period of validity of their bids. The request and the responses shall be made in writing. If a Bid Security is requested in accordance with ITB Clause 20, it shall also be extended for a corresponding period. A Bidder may refuse he request without forfeiting its Bid Security. A Bidder granting the request shall not be required or permitted to modify its bid.</p>

<p>20. Bid Security</p>	<p>20.1 The Bidder shall furnish as part of its bid, a Bid Security as specified in the BDS.</p> <p>20.2 The Bid Security shall be in the amount specified in the BDS and denominated in Sri Lanka Rupees, and shall:</p> <p>(a) at the bidder's option, be in the form of either a bank draft, a letter of credit, or a bank guarantee from a banking institution;</p> <p>(b) be issued by a institution acceptable to Purchaser. The acceptable institutes are published in the NPA website, www.npa.gov.lk.</p> <p>(c) be substantially in accordance with the form included in Section IV, Bidding Forms;</p> <p>(d) be payable promptly upon written demand by the Purchaser in case the conditions listed in ITB Clause 20.5 are invoked;</p> <p>(e) be submitted in its original form; copies will not be accepted;</p> <p>(f) Remain valid for the period specified in the BDS.</p> <p>20.3 Any bid not accompanied by a substantially responsive Bid Security in Accordance with ITB Sub-Clause 20.1 and 20.2, may be rejected by the Purchaser as non-responsive.</p> <p>20.4 The Bid Security of unsuccessful Bidders shall be returned as promptly as possible upon the successful Bidder's furnishing of the Performance Security pursuant to ITB Clause 43.</p> <p>20.5 The Bid Security may be forfeited:</p> <p>(a) if a Bidder withdraws its bid during the period of bid validity specified by the Bidder on the Bid Submission Form, except as provided in ITB Sub- Clause 19.2; or</p>
<p>21.Format and Signing of Bid</p>	<p>21.1 The Bidder shall prepare one original of the documents comprising the bid as described in ITB Clause 11 and clearly mark it as "ORIGINAL". In addition, the Bidder shall submit a copy of the bid and clearly mark it as "COPY. "In the event of any discrepancy between the original and the copy, the original shall prevail.</p> <p>21.2 The original and the Copy of the bid shall be typed or written in indelible ink and shall be signed by a person duly authorized to sign on behalf of the Bidder.</p>

	<p>21.3 Any interlineations, erasures, or overwriting shall be valid only if they are signed or initialed by the person signing the Bid.</p>
<p>Submission and Opening of Bids</p>	
<p>22.Submission Sealing and Marking of Bids</p>	<p>22.1 Bidders may always submit their bids by mail or by hand.</p> <p>(a) Bidders submitting bids by mail or by hand, shall enclose the original and the copy of the Bid in separate sealed envelopes, duly marking the envelopes as “ORIGINAL” and “COPY.” These envelopes containing the original and the copy shall then be enclosed in one single envelope.</p> <p>22.2 The inner and outer envelopes shall:</p> <p>(a) Bear the name and address of the Bidder; be addressed to the Purchaser in accordance with ITB Sub-Clause 23.1;</p> <p>(c) bear the specific identification of this bidding process as indicated in the BDS; and</p> <p>(d) Bear a warning not to open before the time and date for bid opening, in accordance with ITB Sub-Clause 261. If all envelopes are not sealed and marked as required, the Purchaser will assume no responsibility for the misplacement or premature opening of the bid</p>
<p>23.Deadline for Submission of Bids</p>	<p>23.1 Bids must be received by the Purchaser at the address and no later than the date and time specified in the BDS.</p> <p>23.2 The Purchaser may, at its discretion, extend the deadline for the submission of bids by amending the Bidding Documents in accordance with ITB Clause 8, in which case all rights and obligations of the Purchaser and Bidders previously subject to the deadline shall thereafter be subject to the deadline as extended.</p>
<p>24.Late Bids</p>	<p>24.1 The Purchaser shall not consider any bid that arrives after the deadline for submission of bids, in accordance with ITB Clause 23. Any bid received by the Purchaser after the deadline for submission of bids shall be declared late, rejected, and returned unopened to the Bidder.</p>

<p>25. Withdrawal, and Modification on of Bids</p>	<p>25.1 A Bidder may withdraw, or modify its Bid after it has been submitted by sending a written notice in accordance with ITB Clause 22, duly signed by an authorized representative, and shall include a copy of the authorization in accordance with ITB Sub-Clause 21.2, (except that no copies of the withdrawal notice are required). The corresponding substitution or modification of the bid must accompany the respective written notice. All notices must be:</p> <p>(a) submitted in accordance with ITB Clauses 21 and 22 (except that no copies of the withdrawal notice are required). The corresponding substitution or modification of the bid must accompany the respective written notice. All notices must be:</p> <p>(a) submitted in accordance with ITB Clauses 21 and 22 (except that withdrawal notices do not require copies), and in addition, the respective envelopes shall be clearly marked “WITHDRAWAL,” or “ MODIFICATION”; and</p> <p>(b) Received by the Purchaser prior to the deadline prescribed for submission of bids, in accordance with ITB Clause 23.</p> <p>25.2 Bids requested to be withdrawn in accordance with ITB Sub-Clause 25.1 shall be returned to the Bidders only upon notification of contract award to the successful bidder in accordance with sub clause 41.1.</p> <p>25.3 No bid may be withdrawn, substituted, or modified in the interval between the deadline for submission of bids and the expiration of the period of bid validity specified by the Bidder on the Bid Submission Form or any extension thereof.</p>
<p>26. Bid Opening</p>	<p>26.1 The Purchaser shall conduct the bid opening in public at the address, date and time specified in the BDS.</p> <p>26.2 First, envelopes marked “WITHDRAWAL” shall be opened and read out and the envelope with the corresponding bid may be opened at the discretion of the</p>

	<p>Purchaser. No bid withdrawal shall be permitted unless the corresponding withdrawal notice contains a valid authorization to request the withdrawal and is read out at bid opening. Envelopes marked "MODIFICATION" shall be opened and read out with the corresponding Bid. No Bid modification shall be permitted unless the corresponding modification notice contains a valid authorization to request the modification and is read out at Bid opening. Only envelopes that are opened and read out at Bid opening shall be considered further</p> <p>26.3 All other envelopes shall be opened one at a time, reading out: the name of the Bidder and whether there is a modification; the Bid Prices, including any discounts and alternative offers; the presence of a Bid Security or Bid- Securing Declaration, if required; and any other details as the Purchaser may consider appropriate. Only discounts and alternative offers read out at Bid opening shall be considered for evaluation. No Bid shall be rejected at Bid opening except for late bids, in accordance with ITB Sub Clause 24.1.</p> <p>26.4 The Purchaser shall prepare a record of the Bid opening that shall include, as a minimum: the name of the Bidder and whether there is a withdrawal, or modification; the Bid Price, per lot if applicable, including any discounts, and the presence or absence of a Bid Security. The bids that were opened shall be resealed in separate envelopes, promptly after the bid opening. The bidders representatives who are present shall be requested to sign the attendance sheet. A copy of the record shall be distributed to all Bidders who submitted bids in time.</p>
--	--

Evaluation and Comparison of Bids

<p>27. Confidentiality</p>	<p>27.1 Information relating to the examination, evaluation, comparison, and post- qualification (if applicable) of bids, and recommendation of contract award, shall not be disclosed to bidders or any other persons not officially</p>
----------------------------	---

	<p>concerned with such process until publication of the Contract Award.</p> <p>27.2 Any effort by a Bidder to influence the Purchaser in the examination, evaluation, comparison, and post-qualification of the bids or contract award decisions may result in the rejection of its Bid.</p> <p>27.3 Notwithstanding ITB Sub-Clause 27.2, if any Bidder wishes to contact the Purchaser on any matter related to the bidding process, from the time of bid opening to the time of Contract Award, it should do so in writing.</p>
<p>28. Clarification of Bids</p>	<p>28.1 To assist in the examination, evaluation, comparison and post-qualification of the bids, the Purchaser may, at its discretion, request any Bidder for a clarification of its Bid. Any clarification submitted by a Bidder in respect to its Bid and that is not in response to a request by the Purchaser shall not be considered for purpose of evaluation. The Purchaser's request for clarification and the response shall be in writing. No change in the prices or substance of the Bid shall be sought, offered, or permitted, except to confirm the correction of arithmetic errors discovered by the Purchaser in the Evaluation of the bids, in accordance with ITB Clause 30.</p>
<p>29. Responsiveness of Bids</p>	<p>29.1 The Purchaser's determination of a bid's responsiveness is to be based on the contents of the bid itself.</p> <p>29.2 A substantially responsive Bid is one that conforms to all the terms, conditions, and specifications of the Bidding Documents without material deviation, reservation, or omission. A material deviation, reservation, or omission is one that:</p> <ul style="list-style-type: none"> (a) affects in any substantial way the scope, quality, or performance of the Goods and Related Services specified in the Contract; or (b) limits in any substantial way, inconsistent with the Bidding Documents, the

	<p>Purchaser's right or the Bidder's obligations under the Contract ; or</p> <p>(b) If rectified would unfairly affect the competitive position of other bidders presenting substantially responsive bids. 29.3 If a bid is not substantially responsive to the Bidding Documents, it shall be rejected by the Purchaser and may not subsequently be made responsive by the Bidder by correction of the material deviation, reservation, or omission.</p>
<p>30. Nonconformities, Errors and Omissions</p>	<p>30.1 Provided that a Bid is substantially responsive, the Purchaser may waive any non-conformities or omissions in the Bid that do not constitute a material deviation.</p> <p>30.2 Provided that a bid is substantially responsive, the Purchaser may request that the Bidder submit the necessary information or documentation, within a reasonable period of time, to rectify nonmaterial nonconformities or omissions in the bid related to documentation requirements. Such omission shall not be related to any aspect of the price of the Bid. Failure of the Bidder to comply with the request may result in the rejection of its Bid.</p> <p>30.3 Provided that the Bid is substantially responsive, the Purchaser shall correct arithmetical errors on the following basis:</p> <p>(a) if there is a discrepancy between the unit price and the line item total that is obtained by multiplying the unit price by the quantity, the unit price shall prevail and the line item total shall be corrected, unless in the opinion of the Purchaser there is an obvious misplacement of the decimal point in the unit price, in which case the line item total as quoted shall govern and the unit price shall be corrected;</p> <p>(b) if there is an error in a total corresponding to the addition or subtraction of subtotals, the subtotals shall prevail and the total shall be corrected; and</p> <p>(c) If there is a discrepancy between words and figures, the amount in words shall prevail, unless the amount expressed in words is related</p>

	<p>to an arithmetic error, in which case the amount in figures shall prevail subject to (a) and (b) above.</p> <p>30.4 If the Bidder that submitted the lowest evaluated Bid does not accept the correction of errors, its Bid shall be disqualified and its Bid Security shall be disqualified and its Bid-Securing Declaration shall be executed</p>
<p>31. Preliminary Examination of Bids</p>	<p>31.1 The Purchaser shall examine the bids to confirm that all documents and Technical documentation requested in ITB Clause 11 have been provided, and to determine the completeness of each document submitted.</p> <p>31.2 The Purchaser shall confirm that the following documents and information have been provided in the Bid. If any of these documents or information is missing, the Bid shall be rejected.</p> <p>(a) Bid Submission Form, in accordance with ITB Sub- Clause 12.1;</p> <p>(b) Price Schedules, in accordance with ITB Sub-Clause 12;</p> <p>(c) Bid Security, in accordance with ITB Clause 20.</p>
<p>32. Examination of Terms and Conditions ; Technical Evaluation</p>	<p>32.1 The Purchaser shall examine the Bid to confirm that all terms and conditions specified in the CC and the Contract Data have been accepted by the Bidder without any material deviation or reservation.</p> <p>32.2 The Purchaser shall evaluate the technical aspects of the Bid submitted in accordance with ITB Clause 17, to confirm that all requirements specified in Section V, Schedule of Requirements of the Bidding Documents have been met without any material deviation or reservation.</p> <p>32.3 If, after the examination of the terms and conditions and the technical, evaluation the Purchaser determines that the Bid is not substantially responsive in accordance with ITB Clause 29, the Purchaser shall reject the Bid.</p>

<p>33. Conversion to Single Currency</p>	<p>33.1 If the bidders are allowed to quote in foreign currencies in accordance with sub clause 15.1, for evaluation and comparison purposes, the Purchaser shall convert all bid prices expressed in foreign currencies in to Sri Lankan Rupees using the selling rates prevailed 28 days prior to closing of bids as published by the Central Bank of Sri Lanka. If this date falls on a public holiday the earliest working day prior to the date shall be applicable</p>
<p>34. Domestic Preference</p>	<p>34.1 Domestic preference shall be a factor in bid evaluation only if stated in the BDS. If domestic preference shall be a bid evaluation factor, the methodology for calculating the margin of preference and the criteria for its application shall be as specified in Section III, Evaluation and Qualification Criteria.</p>
<p>35. Evaluation of Bids</p>	<p>35.1 The Purchaser shall evaluate each bid that has been determined, up to this stage of the evaluation, to be substantially responsive.</p> <p>35.2 To evaluate a Bid, the Purchaser shall only use all the factors, methodologies and criteria defined in this ITB Clause 35.</p> <p>35.3 To evaluate a Bid, the Purchaser shall consider the following:</p> <ul style="list-style-type: none"> (a) the Bid Price as quoted in accordance with clause 14; (b) price adjustment for correction of arithmetic errors in accordance with ITB Sub-Clause 30.3; (c) price adjustment due to discounts offered in accordance with ITB Sub-Clause 14.2; and 14.3 (d) adjustments due to the application of the evaluation criteria specified in the BDS from amongst those set out in Section III, Evaluation and Qualification Criteria; (e) Adjustments due to the application of a domestic preference, in accordance with ITB Clause 34 if applicable. <p>35.4 The Purchaser's evaluation o factors, in addition to the factors stated in ITB Sub-</p>

	<p>Clause 35.3, if specified in BDS. These factors may be related to the characteristics, performance, and terms and conditions of purchase of the Goods and Related Services. The effect of the factors selected, if any, shall be expressed in monetary terms to facilitate comparison of bids 35.5 If so specified in the BDS, these Bidding Documents shall allow Bidders to quote for one or more package, and shall allow the Purchaser to award one or multiple package to more than one Bidder. Multiple offers shall not be consider for each item. The methodology of evaluation to determine the lowest-evaluated lot combinations is specified in Section III, Evaluation and Qualification Criteria.</p>
36. Comparison of Bids	<p>36.1 The Purchaser shall compare all substantially responsive bids to determine the lowest-evaluated bid, in accordance with ITB Clause 35.</p>
37. Post Qualification of the Bidder	<p>37.1The Purchaser shall determine to its satisfaction whether the Bidder that is selected as having submitted the lowest evaluated and substantially responsive bid is qualified to perform the Contract satisfactorily.</p> <p>37.2 The determination shall be based upon an examination of the documentary evidence of the Bidder’s qualifications submitted by the bidder, pursuant to ITB Clause 18.</p> <p>37.3 An affirmative determination shall be a prerequisite for award of the Contract to the Bidder. A negative determination shall result in disqualification of the bid, in which event the Purchaser shall proceed to the next lowest evaluated bid to make a similar determination of that Bidder’s capabilities to perform satisfactorily.</p>
38. Purchaser’s Right to Accept Any Bid, and to Reject Any or All Bids	<p>38.1 The Purchaser reserves the right to accept or reject any bid, and to annul the bidding process and reject all bids at any time prior to contract award, without there by incurring any liability to Bidders</p>

Award of Contract

<p>39. Award Criteria</p>	<p>39.1 The Purchaser shall award the Contract to the Bidder whose offer has been determined to be the lowest evaluated bid and is substantially responsive to the Bidding Documents, provided further that the Bidder is determined to be qualified to perform the Contract satisfactorily</p>
<p>40. Purchaser’s Right to Vary Quantities at Time of Award</p>	<p>40.1 At the time the Contract is awarded, the Purchaser reserves the right to increase or decrease the quantity of Goods and Related Services originally specified in Section V, Schedule of Requirements, provided this does not exceed twenty five percent (25%) or one unit whichever is higher and without any change in the unit prices or other terms and conditions of the bid and the Bidding Documents.</p>
<p>41. Notification</p>	<p>41.1 Prior to the expiration of the period of bid validity, the Purchaser shall notify the successful Bidder, in writing, that its Bid has been accepted. 41.2 Until a formal Contract is prepared and executed, the notification of award shall constitute a binding Contract. 41.3 Upon the successful Bidder’s performance security pursuant to ITB Clause 43, the Purchaser will promptly notify each unsuccessful Bidder and will discharge its bid security, pursuant to ITB Clause 20.4.</p>
<p>42. Signing of Contract</p>	<p>42.1 Within Seven (7) days after notification, the Purchaser shall complete the Agreement, and inform the successful Bidder to sign it. 42.2 Within Seven (7) days of receipt of such information, the successful Bidder shall sign the Agreement.</p>
<p>43. Performance Security</p>	<p>43.1 Within fourteen (14) days of the receipt of notification of award from the Purchaser, the successful Bidder, if required, shall furnish the Performance Security in accordance with the CC, using for that purpose the Performance Security Form included in Section VIII Contract forms. The Employer shall promptly</p>

notify the name of the winning Bidder to each unsuccessful Bidder and discharge the Bid Securities of the unsuccessful bidders pursuant to ITB Sub-Clause 20.4.

43.2 Failure of the successful Bidder to submit the abovementioned Performance Security or sign the Contract shall constitute sufficient grounds for the annulment of the award and forfeiture of the Bid Security or execution of the Bid- Securing Declaration. In that event the Purchaser may award the Contract to the next lowest evaluated Bidder, whose offer is substantially responsive and is determined by the Purchaser to be qualified to perform the Contract satisfactorily.

Section VI
Conditions of Contract

1. Definitions

1.1 The following words and expressions shall have the meanings hereby assigned to them:

(a) “Contract” means the contract agreement entered into between the Purchaser and the Supplier, together with the Contract Documents referred to therein, including all attachments, appendices, and all documents incorporated by reference therein.

(b) “Contract Documents” means the documents listed in the Contract Agreement, including any amendments thereto.

(c) “Contract Price” means the price payable to the Supplier as specified in the Contract Agreement, subject to such additions and adjustments thereto or deductions therefrom, as may be made pursuant to the Contract.

(d) “Day” means calendar day.

(e) “Completion” means the fulfillment of the supply of Goods to the destination specified and completion of the Related Services by the Supplier in accordance with the terms and conditions set forth in the Contract.

(f) “CC” means the Conditions of Contract.

(g) “Goods” means all of the commodities, raw material, machinery and equipment, and/or other materials that the Supplier is required to supply to the Purchaser under the Contract.

(h) “Purchaser” means the entity purchasing the Goods and related Services, as specified in the Contract Data.

(i) “Related Services” means the services incidental to the supply of the goods, such as insurance, installation, training and initial maintenance and other such obligations of the Supplier under the Contract.

	<p>(j) “subcontractor” means any natural person, private or government entity, or a combination of the above, to whom any part of the Goods to be supplied or execution of any part of the Related Services is subcontracted by the Supplier, Section VI General Conditions of Contract 51</p> <p>(k) “Supplier” means the natural person, private or government entity, or a combination of the above, whose bid to perform the Contract has been accepted by the Purchaser and is named as such in the Contract Agreement.</p> <p>(l) “The Project Site,” where applicable, means the place named in the Contract Data.</p>
2.Contract Documents	<p>2.1 Subject to the order of precedence set forth in the Contract Agreement, all documents forming the Contract (and all parts thereof) are intended to be correlative, complementary, and mutually explanatory. The Contract Agreement shall be read as a whole.</p>
3. Fraud and Corruption	<p>3.1 The Government of Sri Lanka (GOSL) requires the Purchaser as well as bidders, suppliers, contractors, and consultants to observe the highest standard of ethics during the procurement and execution of such contracts. In pursuit of this policy:</p> <p>(i) “corrupt practice” means offering, giving, receiving, or soliciting, directly or indirectly, of anything of value to influence the action of a public official in the procurement process or in contract execution:</p> <p>(ii) “fraudulent practice” means a misrepresentation or omission of facts in order to influence a procurement process or the execution of a contract;</p> <p>(iii) “Collusive practice” means scheme or arrangement between two or more bidders, with or without the knowledge of the purchaser to establish bid prices at artificial, noncompetitive levels; and</p> <p>(iv) “Coercive practice” means harming or threatening to harm, directly or indirectly, persons or their property to influence their participation in the procurement process or affect the execution of a contracts</p>
	<p>4.1 If the context so requires it, singular means plural and vice versa.</p> <p>4.2 Entire Agreement</p> <p>The Contract constitutes the entire agreement between the purchaser and the Supplier and supersedes all communications negotiations and agreements (whether</p>

	<p>52 Section VII. General Conditions of Contract written or oral) of the parties with respect thereto made prior to the date of Contract.</p> <p>4.3 Amendment No amendment or other variation of the Contract shall be valid unless it is in writing, is dated, expressly refers to the Contract, and is signed by a duly authorized representative of each party thereto.</p> <p>4.4 Severability If any provision or condition of the Contract is prohibited or rendered invalid or unenforceable, such prohibition, invalidity or unenforceability shall not affect the validity or enforceability of any other provisions and conditions of the Contract.</p>
5. Language	<p>5.1 The Contract as well as all correspondence and documents relating to the Contract exchanged by the Supplier and the Purchaser, shall be written in English language. Supporting documents and printed literature that are part of the Contract may be in another language provided they are accompanied by an accurate translation of the relevant passages in the language specified, in which case, for purposes of interpretation of the Contract, this translation shall govern.</p> <p>5.2 The Supplier shall bear all costs of translation to the governing language and all risks of the accuracy of such translation, for documents provided by the Supplier.</p>
6. Joint Venture, Consortium or Association	<p>6.1 If the Supplier is a joint venture, consortium, or association, all of the parties shall be jointly and severally liable to the Purchaser for the fulfillment of the provisions of the Contract and shall designate one party to act as a leader with authority to bind the joint venture, consortium, or association. The composition or the constitution of the joint venture, consortium, or association shall not be altered without the prior consent of the Purchaser</p>
7. Eligibility	<p>7.1 All goods supplied under this contract shall be complied with applicable standards stipulated by the Sri Lanka Standards Institute. In the absence of such standards, the Goods supplied shall be complied to other internationally accepted standards, such as British Standards.</p>
8. Notices	<p>8.1 Any notice given by one party to the other pursuant to the Contract shall be in writing to the address specified in the Contract Data. The term "in writing" means</p>

	<p>communicated in written form with proof of receipt. Section VI General Conditions of Contract 53 8.2 A notice shall be effective when delivered or on the notice's effective date, whichever is later.</p>
9. Governing Law	9.1 The Contract shall be governed by and interpreted in accordance with the laws of the Democratic Socialist Republic of Sri Lanka.
10. Settlement of Disputes	<p>10.1 The Purchaser and the Supplier shall make every effort to resolve amicably by direct informal negotiation any disagreement or dispute arising between them under or in connection with the Contract.</p> <p>10.2 If, after twenty-eight (28) days, the parties have failed to resolve their dispute or difference by such mutual consultation, then either the purchaser or the Supplier may give notice to the other party of its intention to commence arbitration, as hereinafter provided, as to the matter in dispute, and no arbitration in respect of this matter may be commenced unless such notice is given. Any dispute or difference in respect of which a notice of intention to commence arbitration has been given in accordance with this Clause shall be finally settled by arbitration. Arbitration may be commenced prior to or after delivery of the Goods under the Contract. Arbitration proceedings shall be conducted in accordance with the Arbitration Act No;11 of 1995.</p> <p>10.3 Notwithstanding any reference to arbitration herein,</p> <p>(a) The parties shall continue to perform their respective obligations</p> <p>under the Contract unless they otherwise agree; and</p> <p>(b) The Purchaser shall pay the Supplier any monies due the Supplier.</p>
11. Scope of Supply	11.1 The Goods and Related Services to be supplied shall be as specified in the Scheduled of Requirements.
12. Deliver and Documents	12.1 Subject to CC sub-Clause 32.1, the Delivery of the Goods and Completion of the related service shall be in accordance with the Delivery and Completion Schedule specified in the schedule of Requirements. Where applicable the details of shipping and other documents to be furnished by the supplier are specified in the Contract Data.
13. Supplier's Responsibilities	13.1 The Supplier shall supply all the Goods and Related Services included in the scope of supply in accordance with CC clause 11, and the Delivery and Completion Schedule, as per CC clause 12.

14.Contract Price	14.1 Prices charged by the Supplier for the Goods supplied and the Related Services performed under the contract shall not vary from the prices quoted by the supplier in its bid.
15.Terms of payment	<p>15.1 The Contract price shall be paid as specified in the Contract Data.</p> <p>15.2 The Supplier’s request for payment shall be made to the purchaser in writing, accompanied by invoices describing, as appropriate, the Goods delivered and Related Services performed, and by the documents submitted pursuant to CC clause 12 and upon fulfillment of all other obligations stipulated in the contract.</p> <p>15.3 Payments shall be made promptly by the purchaser, but in no case later than twenty eight (28) days after submission of an invoice or request for payment by the supplier, and after the Purchaser has accepted it.</p>
16.Taxes and Duties	16.1 The Supplier shall be entirely responsible for all taxes, duties, license fees, etc., incurred until delivery of the contracted Goods to the purchaser
17.Performance Security	<p>17.1 If required as specified in the Contract Data, the Supplier shall, within fourteen (14) days of the notification of contract award, provide a performance security of Ten percent (10%) of the Contract Price for the performance of the Contract.</p> <p>17.2 The proceeds of the performance Security shall be payable to the purchaser as compensation for any loss resulting from the Supplier’s failure to complete its obligations under the Contract.</p> <p>17.3 As specified in the Contract Data, the performance Security, if required, shall be in Sri Lankan Rupees and shall be in the format stipulated by the purchaser in the contract Data, or in another format acceptable to the purchaser.</p> <p>17.4 The performance security shall be discharged by the purchaser and returned to the supplier not later than twenty-eight (28) days following the date of completion of the supplier’s performance obligations under the contract, including any warranty obligations.</p>
18.Copyright	18.1 The copyright in all drawings, documents, and other materials containing data and information furnished to the purchaser by the supplier herein shall remain vested in the supplier, or if they are furnished to the purchaser directly or through the supplier by any third party, including suppliers of materials, the copyright in such materials shall remain vested in such third party.

<p>19. Confidential Information</p>	<p>19.1 The Purchase and the supplier shall keep confidential and shall not, without the written consent of the other party hereto, divulge to any third party any documents, data or other information furnished directly or indirectly by the other party hereto in connection with the Contract, whether such information has been furnished prior to, during or following completion or termination of the Contract. Notwithstanding the above, the supplier may furnish prior to, during or following completion or termination of the contract .Notwithstanding the above, the Supplier may furnish to its Subcontractor such documents, data and other information it receives from the purchaser to the extent required for the subcontractor to perform its work under the contract, in which event the supplier shall obtain from such sub-contractor an undertaking of confidentiality similar to the imposed on the supplier under CC clause 19.</p> <p>19.2 The purchaser shall not use such documents, data and other information received from the Supplier for any purposes unrelated to the contract. Similarly, the Supplier shall not use such documents, data, and other information received from the purchaser for any purpose other than the performance of the contract.</p> <p>19.3 The above provisions of CC clause 19 shall not in any way modify any undertaking of confidentiality given by either of the parties hereto prior to the date of the contract in respect of the supply or any part thereof.</p> <p>19.4 The provisions of CC Clause 19 shall survive completion or termination, for whatever reason, of the contract</p>
<p>20.Subcontracting</p>	<p>20.1 The Supplier shall notify the purchaser in writing of all subcontracts awarded under the contract if not already specified in the bid. Such notification, in the original bid or later shall not relieve the Supplier from any of its obligation, duties, responsibilities, or liability under the contract.</p> <p>20.2 Subcontracts shall comply with the provisions of CC clauses 3 and 7</p>
<p>21. Specifications and Standards</p>	<p>21.1 Technical Specifications and Drawings</p> <p>(a) The Goods and Related services supplied under this Contract shall conform to the technical specifications and standards mentioned in Section V, Schedule of Requirements and, when no applicable standard is mentioned, the standard shall be equivalent or superior to the official standards whose application is appropriate to the Goods country of origin.</p> <p>(b) The supplier shall be entitled to disclaim responsibility for any design, data, drawing, specification or other</p>

	<p>document, or any modification thereof provided or designed by or on behalf of the purchaser, by giving a notice of such disclaimer to the purchaser.</p> <p>(c) Wherever references are made in the Contract to codes and standards in accordance with which it shall be executed, the edition or the revised version of such codes and standards shall be those specified in the Schedule of Requirements. During Contract execution, any changes in any such codes and standards shall be applied only after approval by the purchaser and shall be treated in accordance with CC clause 32.</p>
22. Packing and Documents	22.1 The supplier shall pack the Goods as is required to prevent their damage or deterioration during transit to their final destination, as indicated in the Contract.
23. Insurance	23.1 Unless otherwise specified in the Contract Data, the Goods supplied under the Contract shall be fully insured against loss or damage incidental to manufacture or acquisition, transportation, storage, and delivery.
24. Transportation	24.1 Unless otherwise specified in the Contract Data, responsibility for arranging transportation of the Goods shall be a responsibility of the supplier.
25. Inspections and Tests	<p>25.1 The Supplier shall at its own expense and at no cost to the purchaser carry out all such tests and/or inspections of the Goods and Related Services as are specified in the Contract Data.</p> <p>25.2 The inspections and tests may be conducted on the premises of the Supplier or its Subcontractor, at point of delivery, and/or at the Goods' final destination, or on another place as specified in the Contract Data. Subject to CC sub-Clause 25.3, if conducted on the premises of the supplier or its Subcontractor, all reasonable facilities and assistance, including access to drawings and production data, shall be furnished to the inspectors at no charge to the purchaser.</p> <p>25.3 The Purchaser or its designated representative shall be entitled to attend the tests and/or inspections referred to in CC sub-Clause 25.2, provided that the purchaser bear all of its own costs and expenses incurred in connection with such attendance including, but not limited to, all traveling and board and lodging expenses.</p> <p>25.4 Whenever the supplier is ready to carry out any such test and inspection, it shall give a reasonable advance notice, including the place and time, to the purchaser. The supplier shall obtain from any relevant third party or manufacturer any necessary permission or consent to</p>

	<p>enable the purchaser or its designated representative to attend the test and/or inspection.</p> <p>25.5 The purchaser may require the Supplier to carry out any test and/or inspection not required by the Contract but deemed necessary to verify that the characteristics and performance of the Goods comply with the technical specifications codes and standards under the contract, provided that the supplier's reasonable costs and expenses incurred in the carrying out of such test and/or inspection shall be added to the Contract price.</p> <p>25.6 The supplier shall provide the purchaser with a report of the results of any such test and/or inspection.</p> <p>25.7 The purchaser may reject any Goods or any part thereof that fail to pass any test and/or inspection or do not conform to the specifications. The Supplier shall either rectify or replace such rejected Goods or parts thereof or make alterations necessary to meet the specifications at no cost to the purchaser, and shall repeat the test and /or inspection, at no cost to the purchaser, upon giving a notice pursuant to CC sub- clause 25.4</p> <p>25.8 The Supplier agrees that neither the execution of a test and/or inspection of the Goods or any part thereof, nor the attendance by the purchaser or its representative, nor the issue of any report pursuant to CC sub- Clause 25.6 shall release the supplier from any warranties or other obligations under the contract.</p>
<p>26. Liquidated Damages</p>	<p>26.1 Except as provide under CC clause 31, if the Supplier fails to deliver any or all of the Goods by the Date(s) of delivery or perform the Related Services within the period specified in the Contract, the purchaser may without prejudice to all its other Contact, the Purchaser may without prejudice to all its other remedies under the Contract, deduct from the Contract price, as liquidated damages, a sum equivalent to the percentage specified in the Contract Data of the delivered price of the delayed Goods or unperformed Services for each week or part thereof of delay of delay until actual delivery or performance, up to a 58 Section VII, General Condition of Contract maximum deduction of the percentage specified in those Contract Data. Once the maximum is reached, the Purchaser may terminate the Contract pursuant to CC Clause 34.</p>

<p>27. Warranty</p>	<p>27.1 The Supplier warrants that all the Goods are new, unused, and of the most recent or current models, and that the incorporate all recent improvements in design and materials, unless provided otherwise in the contract.</p> <p>27.2 Subject to CC Sub- Clause 21.1(b0 the Supplier further warrants that the Goods shall be free from defects arising from any act or omission of the Supplier or arising from design, materials, and workmanship, under normal use in the condition prevailing in the country of final destination.</p> <p>27.3 Unless otherwise specified in the Contract Data, the warranty shall remain valid for twelve (12) months after the Goods, or any portion thereof as the case may be, have been delivered to and accepted at the final destination indicated in the Contract Data.</p> <p>27.4 The Purchaser shall give notice to the Supplier stating the nature of any such defects together with all available evidence thereof, promptly following the discovery thereof. The Purchaser shall afford all reasonable opportunity for the Supplier to inspect such defects.</p> <p>27.5 Upon receipt of such notice, the supplier shall, within the period specified in the Contract Data, expeditiously repair or replace the defective Goods or parts thereof, at no cost to the Purchaser.</p> <p>27.6 If having been notified, the Supplier fails to remedy the defect within the period specified in the Contract Data, the Purchaser may proceed to take within a reasonable period such remedial action as may be necessary, at the Supplier's risk and expense and without prejudice to any other rights which the purchaser may have against the supplier under the Contract</p>
<p>28. Patent Indemnity</p>	<p>28.1 The Supplier shall, subject to the Purchaser's Compliance with CC Sub-clause 28.2, indemnify and hold harmless the purchaser and its employees and officers from and against any and all suits, actions or administrative proceedings, claims, demands, losses, damages, cost, and expense of any nature, including attorney's fees and expenses, which the purchaser may suffer as a result of any infringement or alleged infringement of any patent, utility model, registered design, trademark, copyright, or other intellectual</p>

	<p>property right registered or otherwise existing at the date of the contract by reason of:</p> <p>(a) The installation of the Goods by the Supplier or the use of the Goods in the country where the site is located; and</p> <p>(b) The sale in any country of the products produced by the Goods. Such indemnity shall not cover any use of the Goods or any part thereof other than for the purpose indicated by or to be reasonably inferred from the contract, neither any infringement resulting from the use of the goods or any part thereof, or any products produced thereby in association or combination with any other equipment, plant, or materials not supplied by the supplier, pursuant to the Contract.</p> <p>28.2 If any proceedings are brought or any claim is made against the purchaser arising out of the matters referred to in CC Sub-Clause 28.1, the purchaser shall promptly give the supplier a notice thereof, and the supplier may at its own expense and in the Purchaser's name conduct such proceedings or claim and any negotiations for the settlement of any such proceedings or claim.</p> <p>28.3 If the Supplier fails to notify the Purchaser within twenty eight (28) days after receipt of such notice that it intends to conduct any such proceedings or claim, then the Purchaser shall be free to conduct the same on its own behalf.</p> <p>28.4 The Purchaser shall, at the Supplier's request, afford all available assistance to the Supplier in conducting such proceedings or claim, and shall be reimbursed by the Supplier for all reasonable expenses incurred in so doing.</p> <p>28.5 The Purchaser shall indemnify and hold harmless the Supplier and its employees, offices, and Subcontractors from and against any and all suits, actions or administrative proceedings, claims, demands, losses, damages costs, and expenses of any nature, including attorney's fees and expenses, which the supplier may suffer as a result of any infringement or alleged infringement of any patent, utility model, registered design, trademark, copyright, or other intellectual property right registered or otherwise existing at the date of the Contract arising out of or in connection with any design, data, drawing, specification, or other documents</p>
--	---

	or materials provided or designed by or on behalf of the purchaser
29. Limitation of Liability	<p>29.1 Except in cases of criminal negligence or willful misconduct,</p> <p>(a) The supplier shall not be liable to the Purchaser, whether in contract, tort, or otherwise, for any indirect or consequential loss or damage, loss of use, loss of production, or loss of profits or interest costs, provided that this exclusion shall not apply to any obligation of the Supplier to pay liquidated damages to the Purchaser and</p> <p>(b) The aggregate liability of the Supplier to the Purchaser, whether under the Contract, in tort or otherwise, shall not exceed the total Contract Price, provided that limitation shall not apply to the cost of repairing or replacing defective equipment, or to any obligation of the supplier to indemnify the purchase with respect to patent infringement.</p>
30. Change in laws and regulations	<p>30.1 I unless otherwise specified in the Contract, if after the date of 28 days prior to date of Bid submission, any law, regulation, ordinance, order or bylaw having the force of law is enacted, promulgated, abrogated, or changed in Sri Lanka that subsequently affects the Delivery Date and/or contract price shall be correspondingly increased or decreased, to the extent that her supplier has thereby been affected in the performance of any of its obligations under the contract. Notwithstanding the foregoing, such additional or reduced cost shall not be separately paid or credited if the same has already been accounted for in the price adjustment provisions where applicable, in accordance with CC Clause 14.</p>
31. Force Majeure	<p>31.1 The Supplier shall not be liable for forfeiture of its performance security, liquidated damages, or termination or default if and to the extent that its obligations under the contract is the result of an event of Force Majeure.</p> <p>31.2 For purposes of this clause, “Force Majeure” means an event or situation beyond the control of the Supplier that is not foreseeable, is unavoidable, and its origin is not due to negligence or lack of care on the part of the Supplier. Such events may include, but not be limited to, acts of the</p> <p>Purchaser in its sovereign capacity, wars or revolutions, fires, floods, epidemics, quarantine restrictions, and freight embargoes.</p>

	<p>31.3 If a Force Majeure situation arises, the Supplier shall promptly notify the Purchaser in writing of such condition and the cause thereof. Unless otherwise directed by the Purchaser in writing, the supplier shall continue to perform its obligations under the Contract as far as is reasonably practical, and shall seek all reasonable alternative means for performance not prevented by the Force Majeure event.</p>
<p>32. Change orders and Contract Amendments</p>	<p>32.1 The Purchaser may at any time order the Supplier through notice in accordance CC Clause 8, to make changes within the general scope of the Contract in any one or more of the following:</p> <ul style="list-style-type: none"> (a) drawings, designs, or specifications, where Goods to be furnished under the Contract are to be specifically manufactured for the Purchaser; (b) the method of shipment or packing; (c) the place of delivery; and (d) The Related Services to be provided by the wsupplier. <p>32.2 If any such change causes and increase or decrease in the cost of, or the time required for, the Supplier's performance of any provisions under the Contract, an equitable adjustment shall be made in the Contract Price or in the delivery/Completion Schedule, or both, and the Contract shall accordingly be amended. Any claims by the Supplier for adjustment under this clause must be asserted within twenty-eight (28) days from the date of the Supplier's receipt of the Purchaser's change order.</p> <p>32.2 Prices to be charged by the Supplier for any Related Services that might be needed but which were not included in the Contract shall be agreed upon in advance by the parties and shall not exceed the prevailing rates charged to other parties by the Supplier for similar services.</p> <p>32.3 Subject to the above, no variation in or modification of the terms of the Contract shall be made except by written amendment signed by the parties.</p>
<p>33. Extensions of Time</p>	<p>33.1 If at any time during performance of the Contract, the Supplier or its subcontractors should encounter conditions impeding timely delivery of the Goods or completion of Related Services pursuant to CC Clause 121 the supplier shall promptly notify the Purchaser in writing of the Delay, its likely duration, and its cause. As soon as practicable after receipt of the Supplier's notice, the Purchaser in writing of the delay, its likely duration, and its cause. As soon as practicable after receipt of the Supplier's notice, the Purchaser shall evaluate the situation and may at its discretion extend the Supplier's time for performance, in which case the extension shall be ratified by the parties by amendment of the Contract.</p>

	<p>33.2 Except in case of Force Majeure, as provided under CC Clause 31, a delay by the Supplier in the performance of its Delivery and Completion obligations shall render the Supplier liable to the imposition of liquidated damages pursuant to CC Clause 25, unless an extension of time is agreed upon, pursuant to CC Sub- Clause 33.1.</p>
<p>34. Termination</p>	<p>34.1 Termination for Default</p> <p>(a) The purchaser, without prejudice to any other remedy for breach of Contract, by written notice of default sent to the Supplier, may terminate the Contract in whole or in part;</p> <p>(i) If the Supplier fails to deliver any or all of the Goods within the period specified in the Contract, or within any extension thereof granted by the purchaser pursuant to CC-Clause 33;</p> <p>(ii) If the supplier fails to perform any other obligation under the Contract; or</p> <p>(iii) If the Supplier, in the judgment of the purchaser has engaged in fraud and corruption, as defined in CC clause 3 in competing for or in executing the Contract.</p> <p>(b) In the event the purchaser terminates the Contract in whole or in part, pursuant to CC clause 34.1(a), the Purchaser may procure, upon such terms and in such manner as it deems appropriate, Goods or Related Services similar to those undelivered or not performed, and the supplier shall be liable to the Purchaser for any additional costs for such similar Goods or Related Services. However, the Supplier shall continue performance of the Contract to the extent not terminated</p> <p>34.2 Termination for Insolvency.</p> <p>(a) The Purchaser may at any time terminate the Contract by giving notice to the Supplier if the Supplier becomes bankrupt or otherwise insolvent. In such event, termination will be without compensation to the Supplier, Provided that such termination will not prejudice or affect any right of action or remedy that has accrued or will accrue thereafter to the Purchaser</p> <p>34.3 Termination for Convenience</p> <p>(a) The Purchaser, by notice sent to the Supplier, may terminate the Contract, in whole or in part, at any time for its convenience. The notice of termination shall specify that termination is for the Purchaser's convenience, the extent to which performance of the Supplier under the Contract is terminated, and the date upon which such termination becomes effective.</p> <p>(b) The Goods that are complete and ready for shipment within twenty-eight (28) days after the supplier's receipt</p>

	<p>of notice of termination shall be accepted by the Purchaser at the Contract terms and prices. For the remaining Goods, the Purchaser may elect:</p> <p>(i) To have any portion completed and delivered at the Contract terms and prices; and/or</p> <p>(ii) To cancel the remainder and pay to the Supplier an agreed amount for partially completed Goods and Related services and for materials and parts previously procured by the Supplier</p>
35. Assignment	<p>35.1 Neither the Purchaser nor the Supplier shall assign, in whole or in part, their obligations under this Contract, except with prior written consent of the other party.</p>

Section VIII

Contract Forms

1. Contract Agreement

THIS CONTRACT AGREEMENT is made

The [insert: number] day of [insert: month], [insert: year].

BETWEEN

- (1) [Insert complete name of Purchaser], a [insert description of type of legal entity, for example, an agency of the Ministry of..... or corporation and having its principal place of business at [insert address of Purchase] (hereinafter called “the Purchaser”), and
- (2) [Insert name of Supplier], a corporation incorporated under the laws of [insert: country of Supplier] and having its principal place of business at [insert: address of Supplier] (hereinafter called “the Supplier”).

WHEREAS the Purchaser invited bids for certain Goods and ancillary services, viz, [insert : brief description of Goods and Services] and has accepted a Bid by the Supplier for the supply of those Goods and Services in the sum of [insert Contract price in words and figures, expressed in the Contract currency (ies)] (hereinafter called “the Contract Price”).

NOW THIS AGREEMENT WITNESSETH AS FOLLOWS:

1. In this Agreement words and expressions shall have the same meanings as are respectively assigned to them in the Conditions of Contract referred to.
2. The following documents shall constitute the Contract between the Purchaser and the Supplier, and each shall be read and construed as an integral part of the Contract:
 - (a) This Contract Agreement
 - (b) Contract Data
 - (c) Conditions of Contract
 - (d) Technical Requirement (including Schedule of Requirements and Technical Specifications)
 - (e) The Supplier’s Bid and original price Schedules
 - (f) The Purchaser’s Notification of Award

(g) [Add here any other documents(s)]

3. This Contract shall prevail over all other Contract documents. In the event of any discrepancy or inconsistency within the Contract documents, then the documents shall prevail in the order listed above.

4. In consideration of the payments to be made by the Purchaser to the Supplier as hereinafter mentioned, the Supplier hereby covenants with the Purchaser to provide the Goods and Services and to remedy defects therein in conformity in all respects with the provisions of the Contract.

5. The Purchaser hereby covenants to pay the Supplier in consideration of the provision of the Goods and Services and the remedying of defects therein, the Contract Price or such other sum as may become payable under the provisions of the Contract at the times and in the manner prescribed by the Contract.

IN WITNESS whereof the parties hereto have this Agreement to be executed in accordance with the laws of Democratic Socialist Republic of Sri Lanka on the day, month and year indicated above.

For and on behalf of the Purchaser

Signed: [insert signature]

in the capacity of [insert title or other appropriate designation]

in the presence of [insert identification of official witness]

For and on behalf of the Supplier

Signed: [insert signature of authorized representative(s) of the Supplier]

in the capacity of [insert title or other appropriate designation]

in the presence of [insert identification of official witness]

2. Performance Security

[The issuing agency, as requested by the successful Bidder, shall fill in this form in accordance with the instructions indicated] ----- [Issuing Agency's Name, and Address of Issuing Branch of Office] ----- * Beneficiary: ----- [Name and Address of Employer] ---

Date: -----

PERFORMANCE GUARANTEE No: -----

We have been informed that ----- [name of Supplier] (hereinafter called "the Supplier") has entered into Contract No. ----- [Reference number of the contract] dated -----
- with you, for the ----- Supply of ----- [name of contract and brief description]

Furthermore, we understand that, according to the conditions of the Contract, a performance guarantee is required. At the request of the Supplier, we ----- [name of Agency] hereby irrevocably undertake to pay you any sum or sums not exceeding in total an amount of -----
----- [amount in figures] (-----) [amount in words], such sum being payable in the types and proportions of currencies in which the Contract Price is payable, upon receipt by us of your first demand in writing accompanied by a written statement stating that the Contractor is in breach of its obligation (s) under the Contract, without your needing to prove or to show grounds for your demand or the sum specified therein. This guarantee shall expire, no later than the day of , 20 [insert date, 28 days beyond the scheduled completion date including the warranty period] and any demand for payment under it must be received by us at this office on or before that date.

[signature (s)]

3. Guarantee for Advance Payment

[The issuing agency, as requested by the successful Bidder, shall fill in this form in accordance with the instructions indicated.]

Date: [insert date (as day, month and year) of Bid Submission] ICB No. and title: [insert number and title of bidding process] [issuing agency's letterhead] Beneficiary: [insert legal name and address of Purchaser]

ADVANCE PAYMENT GURANTEE No: [insert Advance payment Guarantee no.]

We, [insert legal name and address of issuing agency], have been informed that [insert complete name and address of Supplier] (hereinafter called "the Supplier") has entered into Contract No. [insert number] dated [insert date of Agreement] with you, for the supply of [insert types of Goods to be delivered] (hereinafter called "the Contract")

Furthermore, we understand that, according to the conditions of the Contract, an advance is to be made against an advance payment guarantee.

At the request of the Supplier, we hereby irrevocably undertake to pay you any sum of sums not exceeding in total an amount of [insert amount(s) in figures and words] upon receipt by us of your first demand in writing declaring that the Supplier is in breach of its obligation under the Contract because the Supplier used the advance payment for purposes other than toward delivery of the Goods.

It is a condition for any claim and payment under this Guarantee to be made that the advance payment referred to above must have been received by the Supplier on its account [insert number and domicile of the account]

This Guarantee shall remain valid and in full effect from the date of the advance payment received by the Supplier under the Contract until [insert date].

[Signature of authorized representative(s) of the issuing agency]

Section II Bidding Data Sheet (BDS)

The following specific data for the goods to be procured shall complement, supplement or amend the provisions in the Instructions to Bidders (ITB). Whenever there is a conflict, the provisions herein shall prevail over those in ITB.

[Instructions for completing the Bid Data Sheet are provided, as needed, in the relevant ITB Clauses.]

Clause Reference	A. General
ITB 1.1	The Purchaser is: Uva Wellassa University
ITB 1.1	The name and identification number of the Contract is Supply, Delivery, Installation and Commissioning of Lab Furniture, Equipment and Other Items for Anatomy Laboratory, Faculty of Medicine, Uva Wellassa University
ITB 2.1	The source of funding is: GOSL
ITB 4.4	Foreign bidders are allowed to participate in bidding: Not allowed
	B. Contents of Bidding Documents
ITB 7.1	For Clarification of bid purposes only, the Purchaser's address is: Attention: Deputy Bursar/ Supplies & Stores Address: Uva Wellassa University, Passara Road, Badulla. Telephone: 055-2226475 E-mail : supply@uwu.ac.lk
	C. Preparation of Bids
ITB 11.1 (e)	The Bidder shall submit the following additional documents: A complete company profile of the bidders including, but not limited to, the following: <ul style="list-style-type: none"> • Business Registration Certificate • VAT Registration and VAT Clearance Certificate • List of client who use the Products and their contract details • Past 3 years relevant experience in the relevant Industry in Sri Lanka (The bidder should have at least three years of experience in the relevant industry in Sri Lanka and should submit documents to prove experience in the industry.) • Manufacturer's Authorization. • Certificate of Registration under Public Contract Act. • Financial statements for last 3 years
ITB 15.1	The bidder shall quote the local expenditure in Sri Lankan Rupees.
ITB 18.1 (b)	After sales service is: Required
ITB 19.1	The bid shall be valid for : 90 days from 17 th October 2023
ITB 20.1	Bid shall include a Bid Security in any of following ways (a) A Bank guarantee issued by a reputed bank operated in Sri Lanka.

	(b) Cash deposit at the Shroff Counter of the University (c) Cash deposit from any branch of Bank of Ceylon, to the Uva Wellassa University, Account No: 3114820, and the customer copy of the cash receipt/deposit slip to be attached with the bidding documents.
ITB 20.2	The amount of the Bid Security shall be: As per the schedule of package Beneficiary: Vice Chancellor, Uva Wellassa University. The validity period of the bid security shall be 120 days from the closing date of the Bid
	D. Submission and Opening of Bids
ITB 22.2 (c)	The inner and outer envelopes shall bear the following identification marks: Supply, Delivery, Installation and Commissioning of Lab Furniture, Equipment and Other Items for Anatomy Laboratory, Faculty of Medicine, Uva Wellassa University
ITB 23.1	For bid submission purposes, the Purchaser's address is:
	Attention : Deputy Bursar/Stores & Supplies Address : Uva Wellassa University, Passara Road, Badulla.
	The deadline for the submission of bids is
	Date : 17.10.2023 Time : 2.30 p.m.
ITB 26.1	The bid opening shall take place at:
	Address : Senate Boardroom, Uva Wellassa University, Passara Road, Badulla. Date : 17.10.2023 Time : 2.30 p.m.
	E. Evaluation and Comparison of Bids
ITB 34.1	Domestic preference shall not be a bid evaluation factor.
ITB 35.3(d)	The adjustments shall be determined using the following criteria, from amongst those set out in Section III, Evaluation and Qualification Criteria: (a) Deviation in Delivery schedule: Option 2 _Please refer - CC 26.1 (b) Deviation in payment schedule: Not applicable (c) The cost of major replacement components, mandatory spare parts, and service: Applicable
ITB 35.5	Bidders shall be allowed to quote for one or more package. [refer to Section III Evaluation and Qualification Criteria]Purchaser will evaluate the bid item by item basis.

Schedule of Package

Package	Item No	Name of the Item	Qty	Total Bid Security Rs.
Package 1	1	Gang Chair with Polymer Plastic/Steel Four Seats	2	23,000.00
	2	Museum Table	3	
	3	Visitors chair	7	
	4	Wooden Lab Stools	60	
	5	Key Holder Cabinet	1	
	6	Display cupboard	6	
	7	Office table	8	
	8	Executive Table (small)	1	
	9	Computer Chairs	6	
	10	Office Cupboards	6	
Package 2	11	Tanks for Storing Cadavers	2	
	12	Autopsy Tables	3	
	13	Trolleys	5	
Package 3	14	Dissection Trays	5	48,000.00
	15	Plastic Buckets	6	
	16	Scissors	10	
	17	Mayo scissors	2	
	18	Mayo scissors	2	
	19	knives	1	

20	knives	5
21	knives	5
22	Scalpel handles	2
23	Needle holder	5
24	Needle holder	5
25	Non-tooth tissue forceps	2
26	Non-tooth tissue forceps	2
27	Non-tooth tissue forceps	2
28	Non-tooth tissue forceps	2
29	Towel forceps	2
30	Towel forceps	2
31	Towel forceps	2
32	Mosquito forceps	2
33	Artery Forceps	2
34	Tooth forceps	10
35	Band Saw Heavy Duty Bone cutter	1
36	Knife Sharpener	1
37	Hand Operated Pedestal Eye Wash and Shower	1
38	Silicon full Face Mask	5
39	Eyepiece with pointers	10
40	Binocular Microscope	3

	41	Post Mortem Instruments set (Autopsy) for lecturers' Dissections	1	
	42	Illuminators (4 in one)	2	
Package 4	43	Laptop	1	54,000.00
	44	Television	2	
	45	Camcorder	1	
	46	Matrix Switches	1	
	47	Washing Machine	1	
Package 5	48	Model of Bronchial tree	1	91,000.00
	49	Model of Kidney L.S.	1	
	50	Model of Showing Structures in Pelvic Cavity of Female	1	
	51	Model of Showing Structures in Pelvic Cavity of Male	1	
	52	Model of Eye Showing Interior Structures	1	
	53	Model of Showing Brain and Spinal Cord	1	
	54	Model of Eye Extra Ocular Muscles Nerves	1	
	55	Model of Ear	1	
	56	Model of Showing Lateral Nasal Wall	1	
	57	Human Skeleton	1	
	58	Hand model showing muscles nerves and vessels	1	
	59	Model showing male reproductive organs	1	
	60	Model showing neck muscles, nerves, blood vessels	1	
	61	Model of Brain	1	

62	Model of shoulder joint	1
63	Model of elbow joint	1
64	Model of hip joint	1
65	Model of Knee Joint	1
66	Trunk Showing Interior Body Structures of Thorax	1
67	Model of Heart (I)	1
68	Head and Neck mid sagittal view model	1
69	Model Showing GIT	1
70	Upper Limb Model Showing Muscles, Nerves and Vessels	1
71	Model of Heart(II)	1
72	Lower Limb model showing muscles,nerves and vessels	1
73	Model of Larynx	1
74	Model of kidney liver	1
75	Model of pancreas	1
76	Foot Skeletal with Ligaments & Muscles	1
77	Life Size Model Tarso	1
78	Deluxe Muscle Leg Model	1
79	Life Size Deluxe Muscle Arm Model	1
80	Head with Neck Model	1
81	Highly Flexible Spine with Pelvis	1
82	Dual Sex Urinary System anatomical Model	1

83	Segmented Lung Model	1
84	Liver with Gall Bladder	1
85	Stomach Anatomical Model	1
86	Larynx Model	1
87	Adult Human Skull Model Colour corded kit	1
88	Ear Model	1
89	Knee Joint Model	1
90	Elbow Joint Model	1
91	Shoulder Joint Model	1
92	Hip Joint Model	1
93	Skull Model with facial Muscles	1
94	Section of Skin I	1
95	Section of Skin II	1

Section III Evaluation and Qualification Criteria

1. Evaluation Criteria [ITB 35.3 (d)]

The Purchaser's evaluation of a bid may take into account, in addition to the Bid price quoted in accordance with ITB Clause 14, one or more of the following factors as specified in ITB Sub-Clause 35.3 (d) and in BDS referring to ITB 35.3(d), using the following criteria and methodologies.

(a) Delivery schedule

Option 2

The goods covered under this invitation are required to be delivered within an acceptable range of weeks specified in the Schedule of Requirement. No credit will be given to earlier deliveries, and bids offering delivery beyond this range will be treated as nonresponsive. Within this acceptable range, an adjustment per week, as specified in the Bid Data Sheet, will be added for evaluation purposes only, to the bid price of bids offering deliveries later than the earliest delivery period specified in the Section V, Schedule of Requirements

(a) Deviation in payment schedule. **Not applicable**

(b) Cost of major replacement components, mandatory spare parts, and service: **Not applicable**

(c) Specific additional criteria: **None**

2. Evaluation Criteria (ITB 35.4)

3. Multiple Contracts (ITB 35.5)

The Purchaser shall award multiple contracts to the Bidder that offers the lowest evaluated combination of bids (one contract per bid) and meets the post-qualification criteria (this Section III, Sub-Section ITB 37.2 Post-Qualification Requirements)

The Purchaser shall:

(a) Evaluate only package or item contracts that include items per lot and quantity per item

(b) Take into account: The lowest-evaluated bid for each lot or item

4. Post qualification Requirements (ITB 37.2)

After determining the lowest-evaluated bid in accordance with ITB Sub-Clause 36.1, the Purchaser shall carry out the post qualification of the Bidder in accordance with ITB Clause 37, using only the requirements specified. Requirements not included in the text below shall not be used in the evaluation of the Bidder's qualification.

Qualification Criteria:

(a) Bid may be submitted by any reputed supplier of registered business in Sri Lanka or any accredited local agent who takes fullest responsibility for the whole bid. The local agent shall submit evidence of status, obligations, power of attorney and any other documentary evidence that he is duly authorized and eligible to bid on behalf of the manufacturer.

(b) The bidders should also have previous experience of at least three years in relevant industry in the supply and also technical and financial capability necessary to perform the contract.

(c) Bids will be rejected as non- responsive if documentary evidence in proof of above has not been provided.

(d) If an Agent submits bids on behalf of more than one supplier, unless each such bid is accompanied by a separate Bid Form for each bid, and security when required for each bid, and authorization from the respective Manufacturer, and valid vendor certificate, all such bids will be rejected as non- responsive.

(e) Bidders should possess the Certificate of Business Registration issued by a Governmental Authority/ Registrar of Companies/ Provincial Registrar of Business in the relevant category.

(f) Bidders offering goods under their own brand names should provide along with their bids a current certification/s of quality; Bid not complying with this requirement may be treated as non- responsive.

5. Domestic Preference (ITB 34.1) – **Applicable to Ministry of Finance, Public Finance Circular No. 03/2020**

Section IV
Bidding Forms

Bid Submission Form.

[The Bidder shall fill in this Form in accordance with the instructions indicated no alterations to I format shall be permitted and so substitutions shall be accepted.]

Date:

No:

To: **Uva Wellassa University of Sri Lanka**

We, the undersigned, declare that:

(a) We have examined and have no reservations to the Bidding Documents, including Addenda No:

(b) We offer to supply in conformity with the Bidding Documents and in accordance with the Delivery Schedules specified in the Schedule of Requirements the following Goods and Related Service Procure of

(c) The total price of our Bid without VAT, including any discounts offered is:

(d) The total price of our Bid including VAT, and any discounts offered is:

(e) Our bid shall be valid for the period of time specified in ITB sub-Clause 19.1, form the date fixed for the bid submission deadline in accordance with ITB Sub-Clause 23.1, and it shall remain biding upon us and may be accepted at any time before the expiration of that period;

(f) If our bid is accepted, we commit to obtain a performance security in accordance with ITB Clause 43 and CC Clause 17 for the due performance of the Contract;

(g) We have no conflict of interest in accordance with ITB Sub-Clause 4.3;

(h) Our firm, its affiliates or subsidiaries- including any subcontractors or suppliers for any part of the contract-has not been declared blacklisted by the National Procurement Agency;

(i) We understand that bid, together with your written acceptance thereof include in your notification of award, shall constitute a binding contract between us, until a formal contract is prepared and executed.

(j) We understand that you are not bound to accept the lowest evaluated bid or any other bid that you may receive.

Signed:

In the capacity of

Name:

Duly authorized to sign the bid for and on behalf of:

Dated on ----- day of -----

Price Schedule								
Type	No	Description of the item & item Code	1	2	3	4	5	6
			Qty (Nos)	Unit Rate (Rs)	VAT(Rs)	Unit Price With VAT(2+3) (Rs)	Total Without VAT (Rs) (1*2)	Total With VAT (Rs) (1*4)
Package 01	1.	Gang Chair with Polymer Plastic/Steel Four Seats	2					
	2.	Museum Table	3					
	3.	Visitors chair	7					
	4.	Wooden Lab Stools	60					
	5.	Key Holder Cabinet	1					
	6.	Display Cupboard	6					
	7.	Office Table	8					
	8.	Executive Table (small)	1					
	9.	Computer Chairs	6					
	10.	Office Cupboards	6					
	11.	Tanks for Storing Cadavers	2					

12.	Autopsy Tables	3					
13.	Trollies	5					
14.	Dissection Trays	5					
15.	Plastic Buckets	6					
16.	Scissors	10					
17.	Mayo scissors	2					
18.	Mayo scissors	2					
19.	Knives	1					
20.	Knives	5					
21.	Knives	5					
22.	Scalpel handles	2					
23.	Needle holder	5					
24.	Needle holder	5					

	25.	Non-tooth tissue forceps	2					
	26.	Non-tooth tissue forceps	2					
	27.	Non-tooth tissue forceps	2					
	28.	Non-tooth tissue forceps	2					
	29.	Towel forceps	2					
	30.	Towel forceps	2					
	31.	Towel forceps	2					
	32.	Mosquito forceps	2					
	33.	Artery Forceps	2					
	34.	Tooth forceps	10					
	35.	Band Saw Heavy Duty Bone cutter	1					
	36.	Knife Sharpener	1					
	37.	Hand Operated Pedestal Eye Wash and Shower	1					
	38.	Silicon full Face Mask	5					

	39.	Eyepiece with pointers	10					
	40.	Binocular Microscope	3					
	41.	Post Mortem Instruments set (Autopsy) for lecturers' Dissections	1					
	42.	Illuminators (4 in one)	2					
	43.	Laptop	1					
	44.	Television	2					
	45.	Camcorder	1					
	46.	Matrix Switches	1					
	47.	Washing Machine	1					
	48.	Model of Bronchial tree	1					
	49.	Model of Kidney L.S.	1					
	50.	Model of Showing Structures in Pelvic Cavity of Female	1					
	51.	Model of Showing Structures in Pelvic Cavity of Male	1					
	52.	Model of Eye Showing Interior Structures	1					

	53.	Model of Showing Brain and Spinal Cord	1					
	54.	Model of Eye Extra Ocular Muscles Nerves	1					
	55.	Model of Ear	1					
	56.	Model of Showing Lateral Nasal Wall	1					
	57.	Human Skeleton	1					
	58.	Hand model showing muscles nerves and vessels	1					
	59.	Model showing male reproductive organs	1					
	60.	Model showing neck muscles, nerves, blood vessels	1					
	61.	Model of Brain	1					
	62.	Model of shoulder joint	1					
	63.	Model of elbow joint	1					
	64.	Model of hip joint	1					
	65.	Model of Knee Joint	1					
	66.	Trunk Showing Interior Body Structures of Thorax	1					

	67.	Model of Heart (I)	1					
	68.	Head and Neck mid sagittal view model	1					
	69.	Model Showing GIT	1					
	70.	Upper Limb Model Showing Muscles, Nerves and Vessels	1					
	71.	Model of Heart(II)	1					
	72.	Lower Limb model showing muscles, nerves and vessels	1					
	73.	Model of Larynx	1					
	74.	Model of kidney liver	1					
	75.	Model of pancreas	1					
	76.	Foot Skeletal with Ligaments & Muscles	1					
	77.	Life Size Model Tarso	1					
	78.	Deluxe Muscle Leg Model	1					
	79.	Life Size Deluxe Muscle Arm Model	1					
	80.	Head with Neck Model	1					

	81.	Highly Flexible Spine with Pelvis	1					
	82.	Dual Sex Urinary System anatomical Model	1					
	83.	Segmented Lung Model	1					
	84.	Liver with Gall Bladder	1					
	85.	Stomach Anatomical Model	1					
	86.	Larynx Model	1					
	87.	Adult Human Skull Model Colour corded kit	1					
	88.	Ear Model	1					
	89.	Knee Joint Model	1					
	90.	Elbow Joint Model	1					
	91.	Shoulder Joint Model	1					
	92.	Hip Joint Model	1					
	93.	Skull Model with facial Muscles	1					
	94.	Section of Skin I	1					
	95.	Section of Skin II	1					

*Use separate price schedule for options

.....

Signature and seal of the Bidder Date

Total price without Taxes (in SLR):

Total price without Taxes (in Words):

Vat Registration No:

Total price with VAT:

Total price with VAT (in Words):

Maintenance charges as a percentage after the warranty period:

Name of the Authorized persons:

Signature of the Authorized persons:

Date:

Note : Calibration certificate should be provide on request & ISO 9001

Bid Guarantee

[This Bank Guarantee form shall be filled in accordance with the instructions indicated in brackets] -----
----- [insert issuing agency’s name, and address of issuing branch or office] ----- Beneficiary: -----
---- [name (by issuing agency) number] We have been informed that ----- [insert (by issuing agency)
name of the Bidder; if a joint venture, list complete legal names of partners] (hereinafter called “the Bidder”)
has submitted to you its bid dated -----[insert (by issuing agency) date] (hereinafter called “the Bid”)
for the supply of [insert name of Supplier] under Invitation for Bids No. ----- [insert IFB number (:the
IFB”).

Furthermore, we understand that, according to your conditions, Bids must be supported by a Bid Guarantee.
At the request of the Bidder, we ----- [insert name of issuing agency] hereby irrevocably undertake
to pay you any sum of sums not exceeding in total an amount of ----- [insert amount in figures] ----
----- [insert amount in words]) upon receipt by us of your first demand in writing accompanied by a
written statement stating that the Bidder is in breach of its obligations(s) under the bid conditions, because
the Bidder:

- (a) Has withdrawn its Bid during the period of bid validity specified; or
- (b) Does not accept the correction of errors in accordance with the Instructions to Bidders (hereinafter :the
ITB”); or
- (c) having been notified of the acceptance of its Bid by the Purchaser during the period of bid validity, (i)
fails or refuses to execute the Contract Form, if required, or (ii) fails or refuses to furnish the Performance
Security, in accordance with the ITB.

This Guarantee shall expire: (a) if the Bidder is the successful bidder, upon our receipt of copies of the
Contract signed by the Bidder and of the Performance Security issued to you by the Bidder; or
(c) if the Bidder is not the successful bidder, upon the earlier of (i) our receipt of a copy of your notification
to the Bidder that the Bidder was unsuccessful, otherwise it will remain in force up to ----- (insert date)
Consequently, any demand for payment under this Guarantee must be received by us at the office on or
before that date. ----- signature(s) of authorized representative(s)]

Manufacturer's Authorization

[The Bidder shall require the Manufacturer to fill this Form in accordance with the instructions indicated. This letter of authorization should be on the letterhead of the Manufacturer and should be signed by a person with the proper authority to sign documents that are binding on the Manufacturer. The Bidder shall include it in its bid, if so indicated in the BDS.]

Date: [insert date (as day, month and year) of Bid Submission]

No: [insert number of bidding process]

To: [insert complete name of purchaser]

WHEREAS

We [insert complete name of Manufacturer], who are official manufacturers of [insert type of goods manufactured], having factories at [insert full address of Manufacturer's factories], do hereby authorize [insert complete name of Bidder] to submit a bid the purpose of which is to provide the following Goods, manufactured by us [insert name and or brief description of the Goods], and to subsequently negotiate and sign the Contract.

We hereby extend our full guarantee and warranty in accordance with Clause 27 of the Conditions of Contract, with respect to the Goods offered by the above firm.

Signed: [insert signature(s) of authorized representative(s) of the Manufacturer]

Name: [insert complete name(s) of authorized representative(s) of the Manufacturer]

Title: [insert title]

Duly authorized to sign this Authorization on behalf of: [insert complete name of Bidder]

Dated on day of, [insert date of signing]

Section V
Schedule of Requirements

1. List of Goods and Delivery Schedule

(The Purchaser shall fill in this table, with the exception of the column "Bidder's offered Delivery date" to be filled by the Bidder)

Item No	Description of Goods	Qty	Final Destination	Earliest Delivery Date	Latest Delivery Date	Bidder Offered Delivery Date
1.	Gang Chair with Polymer Plastic/Steel Four Seats	2	Faculty of Medicine, Uva Wellassa University of Sri Lanka	04 Weeks	06 Weeks	
2.	Museum Table	3				
3.	Visitors chair	7				
4.	Wooden Lab Stools	60				
5.	Key Holder Cabinet	1				
6.	Display cupboard	6				
7.	Office table	8				
8.	Executive Table (small)	1				
9.	Computer Chairs	6				
10.	Office Cupboards	6				
11.	Tanks for Storing Cadavers	2				
12.	Autopsy Tables	3				
13.	Trollies	5				
14.	Dissection Trays	5				
15.	Plastic Buckets	6				
16.	Scissors	10				
17.	Mayo scissors	2				
18.	Mayo scissors	2				
19.	knives	1				
20.	knives	5				

21.	knives	5				
22.	Scalpel handles	2				
23.	Needle holder	5				
24.	Needle holder	5				
25.	Non-tooth tissue forceps	2				
26.	Non-tooth tissue forceps	2				
27.	Non-tooth tissue forceps	2				
28.	Non-tooth tissue forceps	2				
29.	Towel forceps	2				
30.	Towel forceps	2				
31.	Towel forceps	2				
32.	Mosquito forceps	2				
33.	Artery Forceps	2				
34.	Tooth forceps	10				
35.	Band Saw Heavy Duty Bone cutter	1				
36.	Knife Sharpener	1				
37.	Hand Operated Pedestal Eye Wash and Shower	1				
38.	Silicon full Face Mask	5				
39.	Eyepiece with pointers	10				
40.	Binocular Microscope	3				
41.	Post Mortem Instruments set (Autopsy) for lecturers' Dissections	1				
42.	Illuminators (4 in one)	2				
43.	Laptop	1				
44.	Television	2				
45.	Camcorder	1				
46.	Matrix Switches	1				

47.	Washing Machine	1				
48.	Model of Bronchial tree	1				
49.	Model of Kidney L.S.	1				
50.	Model of Showing Structures in Pelvic Cavity of Female	1				
51.	Model of Showing Structures in Pelvic Cavity of Male	1				
52.	Model of Eye Showing Interior Structures	1				
53.	Model of Showing Brain and Spinal Cord	1				
54.	Model of Eye Extra Ocular Muscles Nerves	1				
55.	Model of Ear	1				
56.	Model of Showing Lateral Nasal Wall	1				
57.	Human Skeleton	1				
58.	Hand model showing muscles nerves and vessels	1				
59.	Model showing male reproductive organs	1				
60.	Model showing neck muscles, nerves, blood vessels	1				
61.	Model of Brain	1				
62.	Model of shoulder joint	1				
63.	Model of elbow joint	1				
64.	Model of hip joint	1				
65.	Model of Knee Joint	1				
66.	Trunk Showing Interior Body Structures of Thorax	1				
67.	Model of Heart (I)	1				

68.	Head and Neck mid sagittal view model	1				
69.	Model Showing GIT	1				
70.	Upper Limb Model Showing Muscles, Nerves and Vessels	1				
71.	Model of Heart(II)	1				
72.	Lower Limb model showing muscles, nerves and vessels	1				
73.	Model of Larynx	1				
74.	Model of kidney liver	1				
75.	Model of pancreas	1				
76.	Foot Skeletal with Ligaments & Muscles	1				
77.	Life Size Model Tarso	1				
78.	Deluxe Muscle Leg Model	1				
79.	Life Size Deluxe Muscle Arm Model	1				
80.	Head with Neck Model	1				
81.	Highly Flexible Spine with Pelvis	1				
82.	Dual Sex Urinary System anatomical Model	1				
83.	Segmented Lung Model	1				
84.	Liver with Gall Bladder	1				
85.	Stomach Anatomical Model	1				
86.	Larynx Model	1				
87.	Adult Human Skull Model Colour corded kit	1				
88.	Ear Model	1				
89.	Knee Joint Model	1				

90.	Elbow Joint Model	1				
91.	Shoulder Joint Model	1				
92.	Hip Joint Model	1				
93.	Skull Model with facial Muscles	1				
94.	Section of Skin I	1				
95.	Section of Skin II	1				

Technical Specifications

The bidder shall follow the following technical requirement and other requirement.

Type	Item No	Name of the Item	Requirement/Specifications		Qty	Bidders Conformity		
						Yes	No	Remarks
Package 01	1	Gang Chair with Polymer Plastic/Steel Four Seats	Size of a chair	Approx. 450mm (L) X 450mm (W) X Approx. 450mm (H) from Floor Level	2			
			Total length of the gang chairs	Approx 1900mm				
			Structure	Steel structure with steel/polymer accessories				
			Back rest	Medium back				
			Finishes	Chromium plated or equivalent				
			Warranty	02 Years				
				Refer -Drawing Schedule item -1				
	2	Museum Table	Table top size	Approx.2100mm (L)x 920mm(W) each	3			
			Table Height	Approx.750mm Each				
			Table top thickness	Approx.25mm Each				
			Table top partition panel	approx. 2100mm(L) x Approx. 200mm(H) with edges finished smooth				
			Underside Panel	Underside panel shall be approx. 150mm space from for free leg movement				
			Material	Melamine with PVC edging and PVC corner guard				

		Color	walnut/similar			
		Warranty	02 Years			
			Refer -Drawing Schedule item -2			
3	Visitors chair	Side arm rest	With chromium plated or equivalent arm rests	7		
		back rest	Medium back			
		Color	Black			
		Material	PVC/ PPR/ HDPE or equivalent with cotton cushion seat			
		Dimensions	Length – 24 (inches)- Approx.			
			Width – 26 (inches)- Approx.			
			Height – 46 (inches)- Approx.			
		Legs	Heavy duty Steel Legs (without castors) with chromium plated or equivalent finish with firmly fixed heavy duty			
Warranty	02 Years					
		Refer -Drawing Schedule item -3				
4	Wooden Lab Stools	Timber	Teak	60		
		Size of Stool	Approx. 350mm X 300mm and Stamford corners			
		Top Thickness	Approx. 25mm			
		Height of Stool	Approx. 675mm			
		Stool legs	4 legs with approx. 32mmx32mm sections			
		Bottom chords	approx. 32mmx 32mm section and approx. 150mm from floor			
		Color	Walnut/teak/equivalent			
		Finish	Melamine board finish			
		Warranty	03 Years			

			Refer -Drawing Schedule item -4				
5	Key Holder Cabinet	Size	Approx.900mm (L) x 600mm (W)x 100mm Thickness	1			
		Framework	18mm melamine board framework,				
		Back panel	6mm thk Melamine/MDF equivalent board				
		Type	Glass fronted				
		Glass and sash	3mm thk clear glass - 2 sashes with lock				
		Color	Walnut/teak or equivalent				
		Finish	Melamine board finish				
		Support	With wall mounted with brackets, braces, mounts etc.				
			Refer -Drawing Schedule item -5				
6	Display cupboard	Size	Approx.800mm (L) x 400mm (W)x 1800mm high	6			
		Framework	18mm melamine board framework,				
		Sashes	Dual sashes two units				
		Shelves	Top unit- with 3 shelves (Removable shelves) Bottom unit- with 2 shelves (Removable shelves)				
		Back panel	6mm thk MDF or equivalent				
		Locks	need locks for top and bottom unit				
		Glass	3mm thk clear glass				
		Color	Walnut/teak or equivalent				
		Finish	Melamine board finish				
		Warranty	02 Years				

			Refer -Drawing Schedule item -6				
7	Office table	Table Size	Approx.1200mm x 600mm each	8			
		Table Height	Approx.750mm Each				
		Panel Thickness	Approx.18mm Each				
		Drawer Box Size	Approx.400mm x 430mm x 600mm each				
		Top Drawer	150mm				
		Bottom Drawer	300mm				
		Handles	Chrome Plated Drawer handle				
		Underside Panel	Underside panel to cover the drawer depth				
		Material	Melamine				
		Cavities	for wiring and data cabling				
		Color	walnut/similar melamine board finish				
		Warranty	02 Years				
					Refer -Drawing Schedule item -7		
8	Executive Table (small)	Executive Table (Small)	Table Height- Approximately 750mm each	1			
		Table Height	Approx.750mm Each				
		Panel Thickness	Approx.25mm Each				
		Table Size	Approx.1400mm x 750mm each				
		Underside Panel	Underside panel shall provide at least 150mm space from for free leg movement				
		Material	Melamine				

		Cavities	for wiring and data cabling			
		Color	walnut/teak or similar			
		Finish	Melamine board finish			
		Warranty	02 Years			
			Refer -Drawing Schedule item -8			
9	Computer Chairs	Arm rest	With arm rest	6		
		Back rest	Low back			
		Color	Black			
		Material	PVC/PPR/HDPE or equivalent with cushion seat			
		Castor wheels	Adjustable & rotatable with castor wheels			
		Dimensions	Length – 24 (inches)- Approx.			
			Width – 26 (inches)- Approx.			
			Height – 46 (inches)- Approx.			
		Structure	Heavy duty steel legs/HDPE/PPR or equivalent			
		Warranty	02 Years			
			Refer -Drawing Schedule item -9			
10	Office Cupboards	Size	Approx.800mm (L) x 400mm (W)x 1800mm high	6		
		Framework	18mm melamine board framework,			
		Sashes	Dual sashes two units			
		Shelves	Top unit- with 3 shelves (Removable shelves) Bottom unit- with 2 shelves (Removable shelves)			
		Back panel	6mm thk melamine or equivalent			
		Locks	need locks for top and bottom unit			

			Glass	3mm thk clear glass for top unit. Bottom units with 18mm melamine sash				
			Color	Walnut or equivalent				
			Finish	Melamine board finish				
			Warranty	02 Years				
				Refer -Drawing Schedule item -10				
Package 02	11	Tanks for Storing Cadavers	stainless steel (7' x 3.5' x 2.5')		2			
	12	Autopsy Tables	Stainless steel (84x30x36 Inch) or equal With edge and collecting		3			
	13	Trollies	Finish	304 grade stainless steel or better		5		
				Fully welded construction				
				In-built gradient for drainage				
			Castors	125mm diameter or larger braked castors				
			Collection vessel	Removable collection vessel				
			Dimension	74 x 24 x 36 inches in dimensions or nearest				
Warranty	02 Years							
Package 03		Dissection Trays	Stainless steel (16" x 12" x 3")		5			
	15	Plastic Buckets	Store body fluids and dissected body parts		6			
	16	Scissors	Stainless Steel 306 grade or higher - 6" sharp		10			
	17	Mayo scissors	curved 140mm		2			
	18	Mayo scissors	curved 160mm		2			
	19	knives	Brain Cutting 3" Stainless steel		1			
	20	knives	Organ Cutting 10"Stainless steel		5			
	21	knives	Body Cutting 10" Stainless steel		5			
	22	Scalpel handles	(BP Handle) (10/1Pk)		2			
	23	Needle holder	159mm, Stainless steel		5			
	24	Needle holder	203mm, Stainless steel		5			

25	Non-tooth tissue forceps	203mm, Stainless steel	2				
26	Non-tooth tissue forceps	178mm, Stainless steel	2				
27	Non-tooth tissue forceps	152mm, Stainless steel	2				
28	Non-tooth tissue forceps	127mm, Stainless steel	2				
29	Towel forceps	89mm, Stainless steel	2				
30	Towel forceps	102mm, Stainless steel	2				
31	Towel forceps	130mm, Stainless steel	2				
32	Mosquito forceps	125mm, Stainless steel	2				
33	Artery Forceps	177mm, Stainless steel	2				
34	Tooth forceps	140mm long (Turnover end 1-2 teeth)	10				
35	Band Saw Heavy Duty Bone cutter	Standard	1				
36	Knife Sharpener	Operating voltage 220V - 240V,	1				
		Wattage 180W or more					
		replaceable grinding wheels minimum width 6"					
37	Hand Operated Pedestal Eye Wash and Shower	Product Name	Emergency shower 01	1			
		Make	Specify				
		Model	Specify				
		Country of Origin	Specify				
		Material	Pipe and all the connection should be stainless				
			steel with epoxy powder coated				
			Pedestal Mounted Eye wash and Body Shower Unit				
		Emergency Shower	Pull Rod operated				
		Eye-wash Fountain	Treadle Foot Pedal Operated				
	Sprays water from showerhead. Rinses eyes and face with						

			clean water via twin spray nozzles.			
			Installation should be done by the supplier			
			Supplier should be ISO certified company			
		Colour	Red, Green. Yellow			
38	Silicon full Face Mask	should meet the standards of EN 136, comfort, durable and chemical resistant, replaceable filter cartridges, Highly elasticized head harness with easy to use, quick-release buckles and rollers for simple donning and adjustment, as well as fast removal. High quality visor and front cover for clear vision, safety and durability.	5			
39	Eyepiece with pointers	WF 10 x18 eyepiece with pointer and rubber cup	10			
40	Binocular Microscope	Body-Inter changeable, inclined Binocular body, 360° rotatable head Eyepieces-Highest quality 10 X wide angle anti fungus field eyepiece. Objectives-Parfocal, antifungus coated 4x, 10x, 40x and 100x (oil immersion)with plan achromatic correction Optical system-Infinity corrected Stage --Horizontal mechanical stage preferably 100 x 140 mm with fine vernier graduations designed with convenient coaxial adjustment for slide manipulation preferably through 30 x 70 mm Sub stage-Abbe condenser focusable, continuously variable iris diaphragm Illuminator-Built-in LED light source with white light. Finish-A durable textured acid resistant finish. Other Features	3			

		I. Should provide with wooden storage box, dust cover, immersion oil.			
		II. Electrical safety certification			
		III. Should work with input 200 to 240Vac 50 Hz supply.			
		must be made of quality stainless steel			
		Should contain at least one item of following;			
		Handle of surgical knife #4			
		Handle of surgical knife #3			
		Bone chisel, at least 170mm long			
		Bone cutting knife, minimum 220mm long			
		Hammer minimum 220mm long			
		Plate bone saw, minimum 320mm long			
		Stainless steel reverse hook,			
		Bone scissors, minimum 140mm long, straight, single joint			
		Fine anatomical scissor, minimum 125mm long , straight			
		Fine anatomical scissor, minimum 125mm long, bend			
41	Post Mortem Instruments set (Autopsy) for lecturers' Dissections	Surgical scissors, minimum 140mm long , straight	1		
		Surgical scissors, minimum 160mm long, straight			
		Full-tooth hemostatic forceps, minimum 140mm long , straight			
		Full-tooth hemostatic forceps, minimum 140mm, bent			
		Tissue clamp, minimum 140mm, straight			
		Tissue forceps, minimum 140mm, pointed tip			
		Tissue forceps, minimum 160mm, pointed tip			
		Medical tweezers, minimum 140mm , flat head			
		Medical tweezers, minimum 160mm , flat head			
		Equipment box which made with non-corrosive material to place all the items			

Package 04	42	Illuminators (4 in one)	Dimension (Length X Width X Thickness-mm) 470 X 545 X 40 or equal		2			
			Viewing area (Length X Width -mm)- 360 X 440 or equal					
			Light source - LED					
	43	Laptop	Intel Core i5 -1235U Processor		1			
			512GB NVMe RAM					
			8GB DDR4 3200 RAM					
			15.6" FHD Display					
	44	Television	Smart TV 55"(Wall mount TV)		2			
	45	Camcorder	Jib kit, Remote Head with Control Box, zoom & Focus Control, Accessory support kit for monitor, Spare Handle for jib, field Monitor, Battery for field monitor, charger for field Monitor, V-Mount Battery, Battery Charger, Counter weight Set, media c)		1			
	46	Matrix Switches	HDMI Converter cable, High speed HDMI Cables		1			
	47	Washing Machine	Washing Capacity -12Kg		1			
			Smart Inverter™ Motor					
10 Year Warranty (DD Motor)								
Turbo Drum™								
3 Motion Washing Technology								
Soft Closing Door								
Stainless Steel Tub- Semi								
LED Touch Display								
Tub Clean								
Auto Restart								
Auto Pre-Wash								
Tempered Glass Lid								
Smart Filter								
Package 05	48	Model of Bronchial tree	Description	Cartilages, trachea with bronchial tree, and the individual segmental bronchi must be shown in natural size.	1.00			
			Make	Specify				

		Country of Origin	Specify				
49	Model of Kidney L.S.	Description	with adrenal gland, vessels and ureter with removable front section to show inner anatomy.	1			
		Make	Specify				
		Country of Origin	Specify				
50	Model of Showing Structures in Pelvic Cavity of Female	Size	life-size	1			
		Description	Should show all the important structures of a woman's pelvic system, the abdomen and pelvic muscles with very details.				
		Make	Specify				
		Country of Origin	Specify				
51	Model of Showing Structures in Pelvic Cavity of Male	Size	life-size	1			
		Description	Should show all the important structures of a man's pelvic system, the abdomen and pelvic muscles with very details.				
		Make	Specify				
		Country of Origin	Specify				
52	Model of Eye Showing Interior Structures	Description	Able to show the detailed internal structure of the eyeball. Cornea, iris, lens, etc.	1			
			Should be able to freely disassembly, including the scleral muscle attachment and part of the				

			choroid also able to be observed.			
		Make	Specify			
		Country of Origin	Specify			
53	Model of Showing Brain and Spinal Cord	Make	Specify	1		
		Country of Origin	Specify			
54	Model of Eye Extra Ocular Muscles Nerves	Description	Should be enlarged at least 3 times, all six muscles of the eye should be displayed. The optic nerve must be shown up to where it enters the base of the skull. Should be able to separate into parts	1		
		Make	Specify			
		Country of Origin	Specify			
55	Model of Ear	Description	Enlarged approximately 3 times, with removable parts	1		
		Make	Specify			
		Country of Origin	Specify			
56	Model of Showing Lateral Nasal Wall	Make	Specify	1		
		Country of Origin	Specify			
57	Human Skeleton	Size	life-size	1		

		Description	all anatomical details of the bone structure must be represented. Skull with removable mandible. Joints should be flexibly mounted, Must be mounted on a stand with castors.			
		Make	Specify			
		Country of Origin	Specify			
58	Hand model showing muscles nerves and vessls	Description	Showing the superficial and internal structures of the human hand, including bones, muscles, tendons, ligaments, nerves, and arteries.	1		
		Size	life-size			
		Make	Specify			
		Country of Origin	Specify			
59	Model showing male reproductive organs	Description	Prostate and penis must be able to remove, and split into two halves at median level. The skin and the fascia of the penis must be able to partly remove so that the vessels and nerves are visible.	1		
		Make	Specify			
		Country of Origin	Specify			

60	Model showing neck muscles, nerves, blood vessels	Description	The superficial musculature and deep muscles, nerves and vessels must be visible. All important anatomical structures of the human head and neck must be detailed.	1			
		Make	Specify				
		Country of Origin	Specify				
61	Model of Brain	Description	able to divide into at least 4 parts. At least one side of the brain be able to be disassembled into: Frontal with parietal lobes, Brain stem with temporal and occipital lobes and Half of cerebellum	1			
		Make	Specify				
		Country of Origin	Specify				
62	Model of shoulder joint	Description	Should be life sized, should show the anatomy and possible physiological movements of the shoulder joint in detail. Should clearly demonstrate abduction, ante version, retroversion, internal and external rotation.	1			

				Bones should be natural casted and the colors should be very realistic. The cartilage on the joint surfaces must be marked in color. Should consist of scapula, clavicle and a portion of the humerus.				
			Make	Specify				
			Country of Origin	Specify				
63	Model of elbow joint	Description		This high-quality deluxe functional elbow joint model with ligaments shows the anatomy and possible physiological movements of the human elbow joint in exceptional detail. This model should clearly demonstrates abduction, ante version, retroversion, internal and external rotation. The bones should be naturally casted and should be extremely realistic. The cartilage on the elbow joint surfaces must be marked in different color. The elbow joint should consist of a portion of the humerus, ulna and radius.	1			
			Make	Specify				

		Country of Origin	Specify				
64	Model of hip joint	Description	Should show the anatomy and possible physiological movements of the human hip joint in detail. should clearly demonstrates abduction, anteversion, retroversion, internal and external rotation.	1			
			Bones should be natural-casted and should be extremely realistic. The cartilage on the joint surfaces should be marked in a different color. Should consist of portions of the femur and a half of a pelvis. Should be mounted on a base for easy display.				
		Make	Specify				
		Country of Origin	Specify				

65	Model of Knee Joint	Description	Should show the anatomy and possible physiological movements of the human knee joint in detail. Should clearly demonstrate abductions, ante version, retroversion, internal and external rotation. Bones should be natural-casted and should be extremely realistic. The cartilage on the knee joint surfaces should be marked in a different color. Should consist of portions of the femur, tibia and fibula, menisci and patella. Should be mounted on a base for easy display.	1			
		Make	Specify				
		Country of Origin	Specify				
66	Trunk Showing Interior Body Structures of Thorax	Description	Should have the ability to remove major organs	1			
		Make	Specify				
		Country of Origin	Specify				
67	Model of Heart (I)	Description	Should be horizontally sectioned at the level of the valve plane. The following parts should be remove from heart:	1			

			Superior vena cava			
			Aorta			
			Front heart wall			
			Upper half of the heart			
		Make	Specify			
		Country of Origin	Specify			
68	Head and Neck mid sagittal view model	Description	Should be represented the outer, superficial and the internal (median section) structures of head and neck. The half head with musculature should be delivered on removable stand for easy display in a classroom. All Important anatomical structures must be present.	1		
		Make	Specify			
		Country of Origin	Specify			
69	Model Showing GIT	Description	Should be in Life-size	1		
			Should demonstrates the entire digestive system including following features			
			Nose			
			Mouth cavity and Pharynx			
			Esophagus			
			GI tract			
			Liver with gallbladder			
			Pancreas			
			Spleen			

			The duodenum, caecum and rectum of the digestive system should be opened. The transverse colon and front stomach wall should be removable from the digestive system for detailed study of the anatomy.				
		Make	Specify				
		Country of Origin	Specify				
70	Upper Limb Model Showing Muscles, Nerves and Vessels	Description	Should illustrate both the superficial and deeper muscles and at least 5 of them should be removable. Tendons, vessels, nerves and bone components of the arm and shoulder should be shown in great detail.	1			
		Make	Specify				
		Country of Origin	Specify				
71	Model of Heart(II)	Description	At least 2-times life-size for easy identification of all anatomical structures and for lessons in big classrooms or lecture halls. The atrium walls and the front heart wall should be removable.	1			
		Make	Specify				
		Country of Origin	Specify				

72	Lower Limb model showing muscles, nerves and vessels	Description	Should illustrate both the superficial and deeper muscles and at least 8 of them should be removable. Tendons, vessels, nerves and bone components of the arm and shoulder should be shown in great detail.	1			
		Make	Specify				
		Country of Origin	Specify				
73	Model of Larynx	Description	has to be medially sectioned	1			
			should show followings:				
			Larynx				
			Hyoid bone				
			Windpipe				
			Ligaments				
			Muscles				
			Vessels				
			Nerves				
		Thyroid gland Thyroid cartilage, 2 muscles and 2 thyroid gland halves be able to be removable from larynx.					
Make	Specify						
Country of Origin	Specify						
74	Model of kidney liver	Make	Specify	1			
		Country of Origin	Specify				
75	Model of pancreas	Description	Should show the pancreas, the gallbladder, and duodenum.	1			

			Make	Specify			
			Country of Origin	Specify			
76	Foot Skeletal with Ligaments & Muscles	Description		Foot and lower leg be able to be disassembled into at least 6 removable parts for detailed study of the foot and ankle. Should be featured with bones, muscles, tendons, ligaments, nerves, arteries, and veins of the foot. The frontal view of the foot should be featured the extensor muscles of the lower leg. The tendons should be followed on their passage under the transverse and crucial crural ligaments all the way to their insertion points. All tendon sheaths of the foot area must be visible. On the dorsal portion of the foot the gastrocnemius muscle has to be removable to reveal deeper anatomical elements. The sole of the foot should be represented in three layers; the first layer displaying the flexor digitorum brevis.	1		
			Make	Specify			

		Country of Origin	Specify				
77	Life Size Model Tarso	Description	This should be a life-size, dual sex model that can be dissected, features a human torso that has the skin removed from one half showing the underlying musculature of the chest, back, abdomen, head and neck. The front wall of the torso should have the ability to detach to reveal the inner structures and organs in very detail. At least, 40 component parts should be able to dissect from the model. This model should come with a suitable roller base.	1			
			At least following parts should be removable:				
			2-part head				
			Brain half				
			M. sternocleido stoideus				
			M. Deltoideus				
			M. Biceps brachii				
			M. Triceps brachii				
			M. Palmaris longus with m. Felxior carpi radialis				
			M. Brachioradialis with m. Extensor carpi radialis				
			Skin of a one arm				

			Muscled leg, upper part			
			Muscle leg, lower part			
			Skin of a one leg			
			Abdominal cover			
			Mammary gland			
			2 removable lungs			
			2-part removable heart			
			Removable Liver			
			2-part removable stomach			
			Removable kidney half			
			4-part removable intestines			
			3-part female genital insert with embryo			
			4-part male genital			
			M. Satorius			
			M. Gluteus maximus			
			M. Rectus femoris			
			M. Gastrocnemius			
			M. Biceps femoris cap. L. with m. semitendinosus			
			Make	Specify		
			Country of Origin	Specify		
78	Deluxe Muscle Leg Model	Description	This should be a life-size muscular leg	1		
			Should have the ability to disassemble into upper and lower leg.			
			Should have the ability to detach following muscles:			

				- Long head of biceps femoris muscle with semitendinous muscle			
				- Sartorius muscle			
				- Gluteus maximus muscle			
				- Rectus femoris muscle			
				- Gastrocnemius muscle			
			Make	Specify			
			Country of Origin	Specify			
79	Life Size Deluxe Muscle Arm Model	Description	This should be a life-size muscular arm		1		
			The following muscles should be able to detach:				
			- Deltoid muscles				
			- Biceps muscle of arm				
			- Triceps muscle of arm				
			- Long palmar muscle with radial flexor muscle of wrist				
			- Brachioradial muscle with radial extensor muscle of wrist				
		Make	Specify				
		Country of Origin	Specify				

80	Head with Neck Model	Description	Should represent the superficial musculature and deep muscles, nerves and vessels. Should be able to dissect into skull cap and brain. Should be delivered on removable baseboard for easy use in a classroom. All important anatomical structures of the human head must be detailed.	1			
		Make	Specify				
		Country of Origin	Specify				
81	Highly Flexible Spine with Pelvis	Description	Should be mounted on a flexible core, adding extra stability to the spine. Following features must be available:	1			
			Complete pelvis and occipital plate				
			Full flexible mounting throughout spine				
			L3-L4 disc prolapsed on spinal column				
			Spinal nerve exits				
			Cervical vertebral artery				
			Pelvis				
		Make	Specify				
Country of Origin	Specify						
82		Description	This model should show:	1			

				Structures of retroperitoneal cavity			
				Large and small pelvis with bones and muscles			
				Inferior vena cava			
				Aorta with its branches including iliacal vessels			
				Upper urinary tract			
				Rectum			
				Kidney with adrenal gland.			
				One front half of a kidney should be removable.			
			Make	Specify			
			Country of Origin	Specify			
		Dual Sex Urinary System anatomical Model					
83	Segmented Lung Model	Description		This Model should show the lungs with representation of the bronchial tree close to the heart, trachea, oesophagus and aorta.	1		
				The Lung should be detachable into two lobes and single segments. The segments should be colour coded and their position should be easily identified in the bronchial tree. The bronchial tree should contain the lobar bronchi and segmental bronchi.			
				All segments should be connected by magnets which			

			allow a safe and easy handling.			
		Make	Specify			
		Country of Origin	Specify			
84	Liver with Gall Bladder	Description	This should show the liver with:	1		
			Ducts			
			Gall bladder			
			Pancreas			
			Duodenum			
			Vessels			
			Extra-hepatic ducts with gallbladder			
		Main pancreatic duct and their orifices				
		Make	Specify			
Country of Origin	Specify					
85	Stomach Anatomical Model	Description	Should show the different and individual layers of the stomach wall. The front half of the stomach should be removable. Following features should be available:	1		
			The lower esophagus			
			Vessels			
			Duodenum			
			Pancreas			
		Nerves				
		Make	Specify			
Country of Origin	Specify					
86	Larynx Model	Description	has to be medially sectioned	1		
			should show followings:			

			Larynx			
			Hyoid bone			
			Windpipe			
			Ligaments			
			Muscles			
			Vessels			
			Nerves			
			Thyroid gland Thyroid cartilage, 2 muscles and 2 thyroid gland halves be able to be removable from larynx.			
		Make	Specify			
		Country of Origin	Specify			
87	Adult Human Skull Model Colour corded kit	Description	Should be a natural cast of a human skull, Should be able to disassemble into its 22 individual bones.	1		
			All the bones/bone pairs should be colored to make identification easier.			
			The different bones should be attached together without affecting the natural anatomy of the skull.			
			The skull should consist of the following individual bones:			
			Parietal bone (left and right)			
			Occipital bone			
			Frontal bone			
			Temporal bone (left and right)			
			Sphenoid bone			

			Ethmoid bone			
			Vomer bone			
			Zygomatic bone (left and right)			
			Upper jaw (maxilla) with teeth (left and right)			
			Palatine bone (left and right)			
			Nasal concha (left and right)			
			Lacrimal bone (left and right)			
			Nasal bone (left and right)			
			Lower jaw (mandible) with teeth			
			Make	Specify		
			Country of Origin	Specify		
88	Ear Model	Description	Should represent outer, middle and inner ear. Should have removable eardrum with hammer, anvil and stirrup, 2-part labyrinth with cochlea and auditory/balance nerve for detailed study. Should include the detail of two removable bone sections to close the middle and inner ear.	1		
		Make	Specify			
		Country of Origin	Specify			

89	Knee Joint Model	Description	The muscles and muscle portions able to be taken off, and muscle origin and insertion points on the femur, tibia, and fibula should be presented.	1			
		Make	Specify				
		Country of Origin	Specify				
90	Elbow Joint Model	Description	should show elbow with individual muscles and the muscular origins and insertions on humerus, radius and ulna. The muscles should be attached to and removed from the corresponding areas of origin and insertion for easy and fast demonstration.	1			
		Make	Specify				
		Country of Origin	Specify				
91	Shoulder Joint Model	Description	must inclusive of the upper half of the humerus, as well as the clavicle and scapula. Besides showing the musculature of the rotator cuff, also should show the origin and insertion points of the shoulder muscles. The following muscles of the shoulder be able to be depicted and detached for a	1			

				clearer understanding of the shoulder joint:			
				M. subscapularis			
				M. supraspinatus			
				M. infraspinatus			
				M. teres minor			
				Upon detaching the individual muscles, all movements of the shoulder joint be able to be carried out, namely:			
				Abduction			
				Adduction			
				Internal rotation			
				External rotation			
				Raising the arms to the front of the body			
				Raising the arms to the back of the body			
				Raising the arms above the horizontal plane and “making circles with the arms”			
			Make	Specify			
			Country of Origin	Specify			

92	Hip Joint Model	Description	should be constructed with the individual muscles as well as the muscle origins and insertions on the femur and the hip bone. The origin and insertion areas of the muscles should be presented. The hip muscles should be mounted on their corresponding regions of origin and insertion and should be removable from the hip joint for a different perspective.	1				
			Make		Specify			
			Country of Origin		Specify			
93	Skull Model with facial Muscles	Description	On a one half:	1				
			Both the face and mastication muscles should be illustrated.					
			On the other half:					
			The muscle origins and insertions should be marked with colors. The jaw should be movable and due to the flexible musculature, the rudimentary chewing motion be able to be demonstrated. Cranium and masseter should be easily detachable.					

		Make	Specify			
		Country of Origin	Specify			
94	Section of Skin I	Description	It should be at least 70 times magnified.	1		
			All layers of the skin (epidermis, dermis, and subcutis) and microscopic structures such as nerves, vessels and tactile corpuscles should be shown in an anatomically accurate representation.			
		Make	Specify			
		Country of Origin	Specify			
95	Section of Skin II	Description	It should be at least 70 times magnified.	1		
			should show a section of human skin in three dimensional form. Individual skin layers should be differentiated, and important structures of the skin such as hair, sebaceous and sweat glands, receptors, nerves and vessels should be shown in detail.			
		Make	Specify			
		Country of Origin	Specify			

Note 01: for all stainless steel items

- Stainless Steel 306 grade or higher is required for the items of all stainless

Note 02: for all the models,

- Clear pictures and full details should be provided
- all the structures must be hand painted and must be very realistic
- all the materials used must be non-hazardous, extremely durable and highest quality

Drawings

Package # 1 – item 1: Gang Chair - Four-Seater 2 Nrs



Package #1 – item 02: Museum table – 3 Nrs

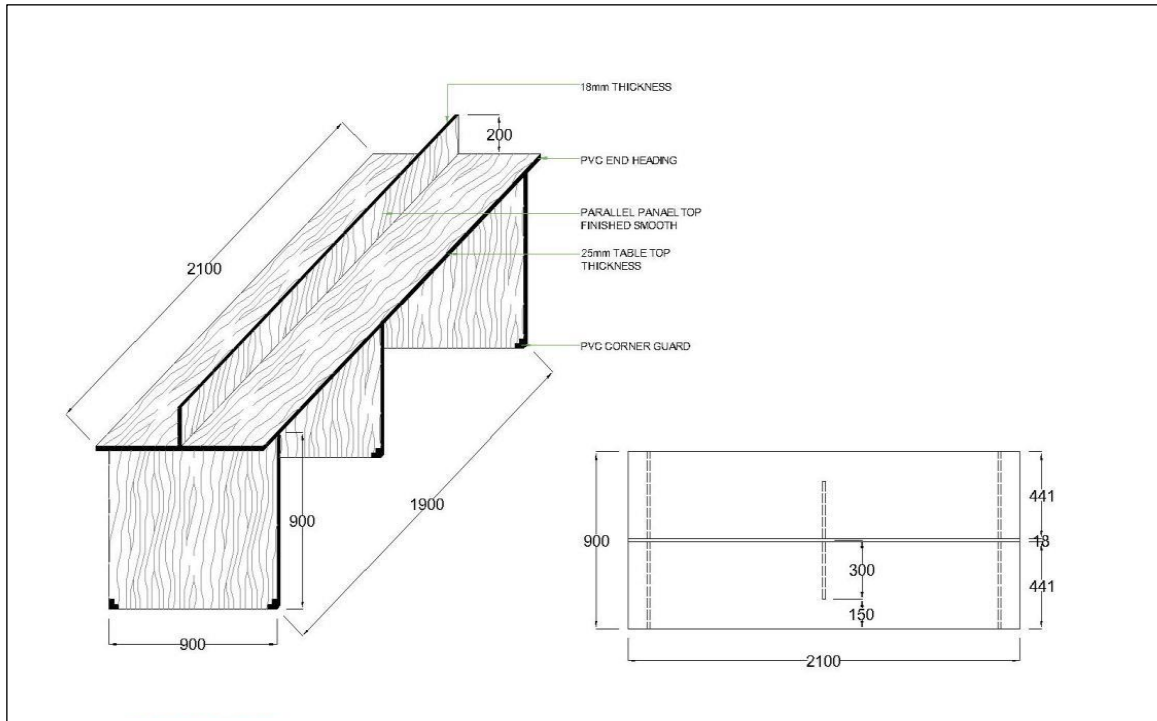

Package #1 – item 03: Visitors Chairs - 07nrs



Package # 01 – item 04: Wooden Lab Stools- 60nrs

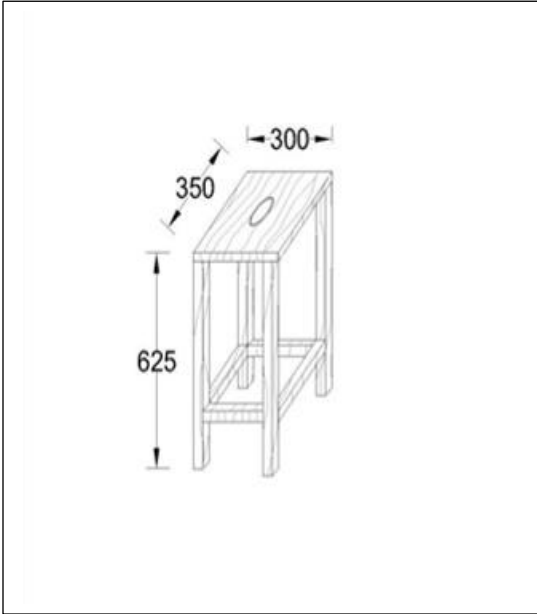

Package # 01 – item 05: Key holder cabinet (Large)

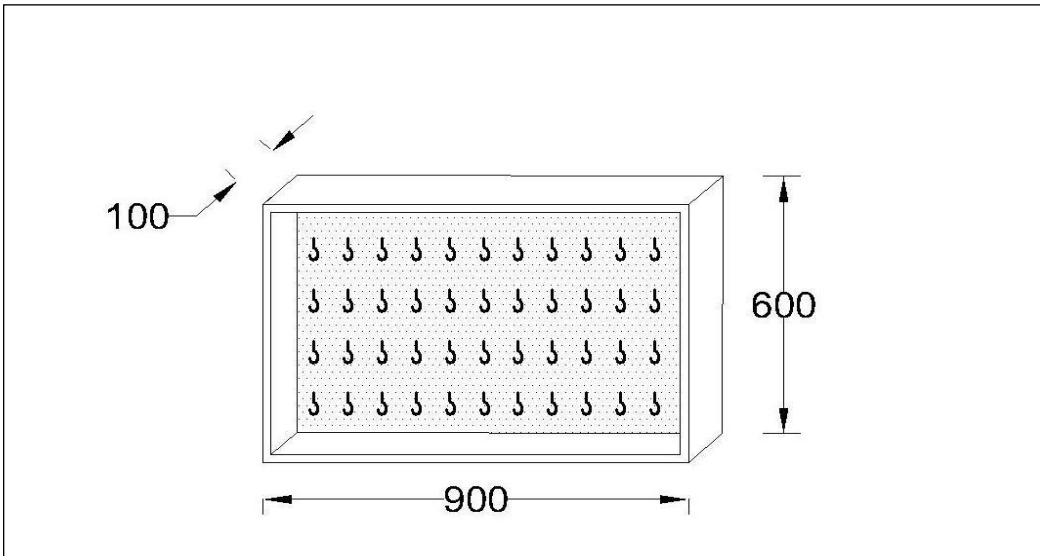

Package #01 – item 06: Laboratory Display Cupboards - 6 Nrs



Package # 01 item 07: Office Tables - 6 Nrs



Package # 01 item 08: Table (to place inside the lab)- 01 Nr



Package # 01 – item 09: Computer Chairs - 6 Nrs



Package # 01 – item 09: Computer Chairs - 6 Nrs



Section VII Contract Data

The Following Contract Data Shall supplements and / or amends the conditions of contract (CC).
Whenever there is a conflict, the provisions herein shall prevail over those in the CC.

CC1.1 (i)	The Purchaser is : Uva Wellassa University of Sri Lanka
CC 1.1 (m)	The Project Site(s) / Final Destinations (s) is / are :- Uva Wellassa University, Passara Road, Badulla
CC 8.1	For notices, the purchaser' s address Attention: - Deputy Bursar, Stores and Supplies Address :- Uva Wellassa University of Sri Lanka, Passara Road, Badulla Telephone: - 055-2226475
CC 11	Goods shall be supplies in compliance with the quality and the specification given.
CC 15.1	CC 15.1 – The method and conditions of payment to be made to the Supplier under this Contract shall be as follows: A: For Goods offered within Sri Lanka Payment shall be made in Sri Lanka Rupees within thirty (30) days of presentation of claim supported by a certificate from the Purchaser declaring that the Goods have been delivered and that all other contracted Services have been performed. (i) On Delivery: up to a maximum of ninety (90) percentage of the Contract price, shall be paid on receipt of the Goods. (ii) On Acceptance: the remaining ten(10) percentage of the Contract price Shall be paid to the Supplier within ninety (90) days. After the certification of acceptance.
CC 17.1	A Performance Security – 10%
CC 26.1	The liquidated damage shall be : 2% per week
CC 26.1	The maximum amount of liquidated damages shall be : 10%

**INVITAION TO BIDS
UVA WELLASSA UNIVERSITY**



**Supply, Delivery, Installation and Commissioning of Lab Furniture, Equipment and
Other Items for Anatomy Laboratory, Faculty of Medicine,
Uva Wellassa University
UWU/G/NCB/FOM/23/02**

The Chairman, Department Procurement Committee, on behalf of the Uva Wellassa University, invites sealed bids from eligible and qualified bidders for **Supply, Delivery, Installation and Commissioning of Lab Furniture, Equipment and Other Items for Anatomy Laboratory, Faculty of Medicine, Uva Wellassa University** as described below.

1. Bidding will be conducted through the National Competitive Bidding (NCB) procedure.
2. Bidder should have at least three years of experience in the relevant field in Sri Lanka.
3. Interested eligible bidders may obtain further information from the Deputy Bursar / Stores and Supplies, Uva Wellassa University, Passara Road, Badulla, (Tel. No: 055-2226475, Fax No: 055-2226633), and inspect the bidding documents at the Supplies Division of the University between 9.00 a.m. to 3.00 p.m. from 25.09.2023 to 16.10.2023.
4. A complete set of bidding documents in English may be purchased by interested bidders on submission of a written application to the Deputy Bursar/ Stores and Supplies, Uva Wellassa University, Passara Road, Badulla and upon payment of a non-refundable fee of LKR 9,000.00 in cash at the Shroff Counter of the University. The bidder can also download the biding documents from the University website www.uwu.ac.lk. Those who are obtaining bidding documents from the University website should submit the complete documents along with a Bank Draft drawn in favour of the “Vice Chancellor, Uva Wellassa University” for LKR 9,000.00 as non-refundable fee or the payments could be made to any branch of Bank of Ceylon, to the Uva Wellassa University, Account No: 3114820, and the customer copy of the cash receipt/deposit slip to be attached with the bidding documents. The documents may be purchased until 16.10.2023.
5. Bids must be delivered to **Chairman, Department Procurement Committee, Uva Wellassa University, Passara Road, Badulla**, on or before **2.30 p.m. on 17th October 2023** Please indicate the “**Supply, Delivery, Installation and Commissioning of Lab Furniture, Equipment and Other Items for Anatomy Laboratory, Faculty**

of Medicine, Uva Wellassa University” on the top left hand corner of the envelope.

6. All bids must be accompanied by a Bid Security addressed to the **Chairman, Department Procurement Committee, Uva Wellassa University**, valid for 120 days from the date of the bid opening specified in the following table.

No	Description	Package	Bid Security Amount Rs.
01	Furniture Items	Package -01	23,000.00
02	Lab Furniture	Package -02	44,000.00
03	Lab Utensils	Package- 03	48,000.00
04	Electrical Appliances	Package- 04	54,000.00
05	Models of Anatomy	Package- 05	91,000.00
Total Bid Security Amount Rs.			260,000.00

7. Pre Bid meeting will be held at **10.00 a.m. on 10th October 2023**, at the Office of the Faculty of Medicine, Uva Wellassa University.
8. The bids shall be deposited in the ‘Tender Box’ available in the Office of the Registrar of the University, or sent under Registered Cover to be received before the deadline to the address given in Clause No.5.
9. Late bids will be rejected. Bids will be opened immediately after the closing of bids, in the presence of the bidders or their authorized representatives who choose to attend the bid opening at the board room of the Uva Wellassa University.

Chairman
Department Procurement Committee
Uva Wellassa University
Passara Road
Badulla
Tel/ Fax No: 055-2226475, 055-2226633