

**DEMOCRATIC SOCIALIST REPUBLIC OF
SRI LANKA**



UVA WELLASSA UNIVERSITY

**SUPPLY, DELIVERY, INSTALLATION AND COMMISSIONING OF
LABORATORY EQUIPMENT FOR DEPARTMENT OF ANIMAL SCIENCE
FACULTY OF ANIMAL SCIENCE AND EXPORT AGRICULTURE**

UWU/G/NCB/18/02

BIDDING DOCUMENT

Bid Opening On	11 th June 2018 - 2.00 p.m.
Bid Validity up to	91 days from 11 th June 2018

Uva Wellassa University
Passara Road,
Badulla,
Sri Lanka.

Deputy Bursar (Stores & Supplies)
Uva Wellassa University
Passara Road, Badulla.

CONTENTS

Content	Page Nos.
Invitation for Bids	03
Section I: Instructions to Bidders (ITB)	04
Section VI: Conditions of Contract (CC)	04
Section VIII: Contract Forms	04
Contract Agreement	05 - 06
Performance Security	07
Section II: Bidding Data Sheet (BDS)	08 - 09
Section III: Evaluation and Qualification Criteria	10 - 11
Section IV: Bidding Forms	12
Form of Bid	13
Price Schedule	14 – 15
Bid security form	16
Manufacturer Authorization	17
Section V: Schedule of Requirements	18
List of goods and delivery schedule	18
Technical specification	18 – 28
Section VII: Contract Data	29

INVITATION FOR BIDS UVA WELLISSA UNIVERSITY



Supply, Delivery, Installation & Commissioning of Laboratory Equipment for Department of Animal Science, Faculty of Animal Science and Export Agriculture UWU/G/NCB/18/02

The Chairman, Department Procurement Committee, on behalf of the Uva Wellassa University, invites sealed bids from eligible bidders and qualified bidders for **Supply, Delivery, Installation & Commissioning of Laboratory Equipment for Department of Animal Science, Faculty of Animal Science and Export Agriculture**

1. Bidding will be conducted through the National Competitive Bidding (NCB) procedure.
2. Bidder should have at least three years' experience in the relevant field in Sri Lanka.
3. Interested eligible bidders may obtain further information from the Deputy Bursar / Supplies, Uva Wellassa University, Passara Road, Badulla, (Tel. No: 055-2226475, Fax No: 055-2226633), and inspect the bidding documents at the Supplies Division of the University between 9.00 am to 3.00 pm from **21st May 2018 to 10th June 2018 and up to 12.30 p.m. on 11/06/2018.**
4. A complete set of bidding documents in English may be purchased by interested bidders on submission of a written application to the Deputy Bursar/ Supplies, Uva Wellassa University, Passara Road, Badulla and upon payment of a non-refundable fee of Rupees 2,700.00 in cash at the Shroff Counter of the University. The bidder can also download the bidding documents from the University website www.uwu.ac.lk. Those who are obtaining bidding documents from the University website should submit the complete documents along with a Bank Draft drawn in favour of the "Vice Chancellor, Uva Wellassa University" for Rs. 2,700.00 as non-refundable fee or the payments could be made to any branch of Bank of Ceylon, to the Uva Wellassa University, Account No: 3114820, and the original of the cash receipt/deposit slip to be attached with the bidding documents. The documents may be purchased until **12.30 p.m. on 11th June 2018.**
5. Bids must be delivered to be addressing **Chairman, Department Procurement Committee, Uva Wellassa University, Passara Road, Badulla**, on or before **2.00 p.m. on 11th June 2018.** Please indicate the "**SUPPLY, DELIVERY, INSTALLATION & COMMISSIONING OF LABORATORY EQUIPMENT FOR DEPARTMENT OF ANIMAL SCIENCE, FACULTY OF ANIMAL SCIENCE AND EXPORT AGRICULTURE - UWU/G/NCB/18/02**" on the top left hand corner of the envelope.
6. All bids must be accompanied by a Bid Security addressed to the **Chairman, Department Procurement Committee, Uva Wellassa University**, valid for 120 days from the date of the bid opening. The Value of the Bid Security shall be **Rs. 112,000.00**
7. Pre Bid meeting will be held at **11.00 a.m. on 30th May 2018**, at the Boardroom of Uva Wellassa University.
8. The bids shall be deposited in the 'Tender Box' available in the Registrar's Office of the University, or sent under Registered Cover to be received before the deadline to the address given in Clause No.5.
9. Late bids will be rejected. Bids will be opened immediately after the closing of bids, in the presence of the bidders or their authorized representatives who choose to attend the bid opening at the board room of the Uva Wellassa University.

Chairman,
Department Procurement Committee,
Uva Wellassa University,
Passara Road,
Badulla
Tel/ Fax No: 055-2226475, 055-2226633

Deputy Bursar (Stores & Supplies)
Uva Wellassa University
Passara Road, Badulla.

Section I.

Instructions to Bidders (ITB)

This Bidding Document is based on the standard bidding document for National Competitive Bidding (NPA/Goods/SBD 01). Section I will not be provided with this bidding document. Bidders are instructed to refer the Section I of the standard bidding document (NPA/Goods/SBD 01). The document is available at the website of NPA, www.npa.gov.lk

Section VI.

Conditions of Contract

This Bidding Document is based on the standard bidding document for National Competitive Bidding (NPA/Goods/SBD 01). Section VI will not be provided with this bidding document. Bidders are instructed to refer the Section VI of the standard bidding document (NPA/Goods/SBD 01). The document is available at the website of NPA, www.npa.gov.lk

Section VIII. Contract Forms

Table of Forms

1. Contract Agreement	4-5
2. Performance Security.....	6

Contract Agreement

THIS CONTRACT AGREEMENT is made

the [insert: number] day of [insert: month], [insert: year].

BETWEEN

(1) [Insert complete name of Purchaser], a [insert description of type of legal entity, for example, an agency of the Ministry of or corporation and having its principal place of business at [insert address of Purchaser] (hereinafter called “the Purchaser”), and

(2) [Insert name of Supplier], a corporation incorporated under the laws of [insert: country of Supplier] and having its principal place of business at [insert: address of Supplier] (hereinafter called “the Supplier”).

WHEREAS the Purchaser invited bids for certain Goods and ancillary services, viz., [insert brief description of Goods and Services] and has accepted a Bid by the Supplier for the supply of those Goods and Services in the sum of [insert Contract Price in words and figures, expressed in the Contract currency (ies)] (hereinafter called “the Contract Price”).

NOW THIS AGREEMENT WITNESSETH AS FOLLOWS:

1. In this Agreement words and expressions shall have the same meanings as are respectively assigned to them in the Conditions of Contract referred to.

2. The following documents shall constitute the Contract between the Purchaser and the Supplier, and each shall be read and construed as an integral part of the Contract:

- (a) This Contract Agreement
- (b) Contract Data
- (c) Conditions of Contract
- (d) Technical Requirements (including Schedule of Requirements and Technical Specifications)
- (e) The Supplier’s Bid and original Price Schedules
- (f) The Purchaser’s Notification of Award
- (g) [Add here any other document(s)]

3. This Contract shall prevail over all other Contract documents. In the event of any discrepancy or inconsistency within the Contract documents, then the documents shall prevail in the order listed above.

4. In consideration of the payments to be made by the Purchaser to the Supplier as hereinafter mentioned, the Supplier hereby covenants with the Purchaser to provide the Goods and Services and to remedy defects therein in conformity in all respects with the provisions of the Contract.

5. The Purchaser hereby covenants to pay the Supplier in consideration of the provision of the Goods and Services and the remedying of defects therein, the Contract Price or such other sum as may become payable under the provisions of the Contract at the times and in the manner prescribed by the Contract.

IN WITNESS whereof the parties hereto have caused this Agreement to be executed in accordance with the laws of Democratic Socialist Republic of Sri Lanka on the day, month and year indicated above.

For and on behalf of the Purchaser

Signed: [insert signature]

in the capacity of [insert title or other appropriate designation]

in the presence of [insert identification of official witness]

For and on behalf of the Supplier

Signed: [insert signature of authorized representative(s) of the Supplier]

in the capacity of [insert title or other appropriate designation]

in the presence of [insert identification of official witness]

Performance Security

[The issuing agency, as requested by the successful Bidder, shall fill in this form in accordance with the instructions indicated] ----- [Issuing Agency's Name, and Address of Issuing Branch or Office] ----- * Beneficiary:----- [Name and Address of Employer] -----

Date: -----

PERFORMANCE GUARANTEE No.: -----

We have been informed that ----- [Name of Supplier] (hereinafter called "the Supplier") has entered into Contract No. ----- [Reference number of the contract] dated ----- with you, for the ----- Supply of ----- [name of contract and brief description] (hereinafter called "the Contract").

Furthermore, we understand that, according to the conditions of the Contract, a performance guarantee is required. At the request of the Supplier, we ----- [name of Agency] hereby irrevocably undertake to pay you any sum or sums not exceeding in total an amount of -----

[Amount in figures] (-----) [amount in words], such sum being payable in the types and proportions of currencies in which the Contract Price is payable, upon receipt by us of your first demand in writing accompanied by a written statement stating that the Contractor is in breach of its obligation(s) under the Contract, without your needing to prove or to show grounds for your demand or the sum specified therein. This guarantee shall expire, no later than the day of, 20.. [Insert date, 28 days beyond the scheduled completion date including the warranty period] and any demand for payment under it must be received by us at this office on or before that date.

[Signature(s)]



Section II. Bidding Data Sheet (BDS)

The following specific data for the goods to be procured shall complement, supplement, or amend the provisions in the Instructions to Bidders (ITB). Whenever there is a conflict, the provisions herein shall prevail over those in ITB.

[Instructions for completing the Bid Data Sheet are provided, as needed, in the relevant ITB Clauses.]

ITB Clause Reference	A. General
ITB 1.1	The Purchaser is: Uva Wellassa University
ITB 1.1	The name and identification number of the Contract are: Supply, Delivery, Installation & Commissioning of Laboratory Equipment for Department of Animal Science, Faculty of Animal Science and Export Agriculture Contract No: UWU/G/NCB/18/02
ITB 1.2	The bidder should have at least three years' experience in the relevant industry in Sri Lanka and should submit documents to prove experience in the industry.
ITB 2.1	The source of funding is: GOSL
ITB 4.4	Foreign bidders are allowed to participate in bidding: Not allowed
	B. Contents of Bidding Documents
ITB 7.1	For Clarification of bid purposes only, the Purchaser's address is: Attention: Deputy Bursar/Supplies Address: Uva Wellassa University, Passara Road, Badulla. Telephone: 055-2226475 Electronic mail : supply@uwu.ac.lk
	C. Preparation of Bids
ITB 11.1 (e)	The Bidder shall submit the following additional documents: A complete company profile of the bidders including, but not limited to, the following: <ul style="list-style-type: none"> • Business Registration Certificate • VAT Registration Certificate • List of client who use the Products • Past 3 years relevant experience in the relevant Industry in Sri Lanka • Manufacturer's Authorization. • Certificate of Registration under Public Contract Act.
ITB 15.1	The bidder shall quote the local expenditure in Sri Lankan Rupees .
ITB 18.1 (b)	After sales service is: Required
ITB 19.1	The bid shall be valid for: 91 days from 11th June 2018
ITB 20.1	Bid shall include a Bid Security in any of following ways <ul style="list-style-type: none"> (a) A Bank guarantee issued by a reputed bank operated in Sri Lanka. (b) Cash deposit at the Shroff Counter of the University (c) Cash deposit from any branch of Bank of Ceylon, to the Uva Wellassa University, Account No: 3114820, and the cash receipt/deposit slip to be attached with the bidding documents.

ITB 20.2	The amount of the Bid Security shall be: Rs. 112,000.00 Beneficiary: Vice Chancellor, Uva Wellassa University. The validity period of the bid security shall be 120 days from the closing date of the Bid
	D. Submission and Opening of Bids
ITB 22.2 (c)	The inner and outer envelopes shall bear the following identification marks: SUPPLY, DELIVERY, INSTALLATION & COMMISSIONING OF LABORATORY EQUIPMENT FOR DEPARTMENT OF ANIMAL SCIENCE, FACULTY OF ANIMAL SCIENCE AND EXPORT AGRICULTURE Contract No: UWU/G/NCB/18/02
ITB 23.1	For bid submission purposes, the Purchaser's address is: Attention: Deputy Bursar Address: Uva Wellassa University, Passara Road, Badulla. The deadline for the submission of bids is Date: 11th June 2018 Time: 2.00 p.m.
ITB 26.1	The bid opening shall take place at: Address: Board Room, Uva Wellassa University, Passara Road, Badulla. Date: 11th June 2018 Time: 2.00 p.m.
	E. Evaluation and Comparison of Bids
ITB 34.1	Domestic preference shall not be a bid evaluation factor.
ITB 35.3(d)	The adjustments shall be determined using the following criteria, from amongst those set out in Section III, Evaluation and Qualification Criteria: (a) Deviation in Delivery schedule: Option 2 is selected and the adjustment is 0.5% per week or part thereof (b) Deviation in payment schedule: Not applicable (c) The cost of major replacement components, mandatory spare parts, and service: Applicable
ITB 35.4	The following factors and methodology will be used for evaluation: Not applicable
ITB 35.5	Bidders shall be allowed to quote for one or more lots. [refer to Section III Evaluation and Qualification Criteria]Purchaser will evaluate the bid item by item basis.

 Deputy Bursar (Stores & Supplies)
 Uva Wellassa University
 Passara Road, Badulla.

Section III.

Evaluation and Qualification Criteria

1. Evaluation Criteria (ITB 35.3 (d))

The Purchaser's evaluation of a bid may take into account, in addition to the Bid Price quoted in accordance with ITB Clause 14, one or more of the following factors as specified in ITB Sub-Clause 35.3(d) and in BDS referring to ITB 35.3(d), using the following criteria and methodologies.

(a) Delivery schedule

Option 2

The goods covered under this invitation are required to be delivered within an acceptable range of weeks specified in the Schedule of Requirement. No credit will be given to earlier deliveries, and bids offering delivery beyond this range will be treated as nonresponsive. Within this acceptable range, an adjustment per week, as specified in the Bid Data Sheet, will be added for evaluation purposes only, to the bid price of bids offering deliveries later than the earliest delivery period specified in the Section V, Schedule of Requirements

(a) Deviation in payment schedule. **Not applicable**

(c) Cost of major replacement components, mandatory spare parts, and service:

The required spare parts for the goods covered under this invitation shall be available for at least five years of period and after sales service (Free service & Pay service).

(d) Specific additional criteria: **None**

2. Evaluation Criteria (ITB 35.4):

Not Applicable

3. Multiple Contracts (ITB 35.5)

The Purchaser shall award multiple contracts to the Bidder that offers the lowest evaluated combination of bids (one contract per bid) and meets the post-qualification criteria (this Section III, Sub-Section ITB 37.2 Post-Qualification Requirements)

The Purchaser shall:

- (a) Evaluate only lots or contracts that include items per lot and quantity per item
- (b) Take into account: The lowest-evaluated bid for each lot

3. Post qualification Requirements (ITB 37.2)

After determining the lowest-evaluated bid in accordance with ITB Sub-Clause 36.1, the Purchaser shall carry out the post qualification of the Bidder in accordance with ITB Clause 37, using only the requirements specified. Requirements not included in the text below shall not be used in the evaluation of the Bidder's qualifications.

Qualification Criteria:

- (a) Bid may be submitted by any reputed supplier of **Laboratory Equipment** , registered business in Sri Lanka or any accredited local agent who takes fullest responsibility for the whole bid. The local agent shall submit evidence of status, obligations, power of attorney and any other documentary evidence that he is duly authorized and eligible to bid on behalf of the manufacturer.
- (b) The bidders should also have previous experience of at least three years in relevant industry in the supply and also technical and financial capability necessary to perform the contract.
- (c) Bids will be rejected as non- responsive if documentary evidence in proof of above has not been provided.
- (d) If an Agent submits bids on behalf of more than one supplier, unless each such bid is accompanied by a separate Bid Form for each bid, and a bid security when required for each bid, and authorization from the respective Manufacturer, and valid vendor certificate, all such bids will be rejected as non- responsive.
- (e) Bidders should possess the Certificate of Business Registration issued by a Governmental Authority/ Registrar of Companies/ Provincial Registrar of Business in the relevant category.
- (f) Bidders shall register the Contract under Public Contract Act and submit the certificate of registration (ITB 11.1(e)).
- (g) Bidders offering goods under their own brand names should provide along with their bids a current certification/s of quality; Bid not complying with this requirement may be treated as non - responsive.
- (h) Having a service center in Badulla or Uva Province will be considered as an added qualification.

4. Domestic Preference (ITB 34.1) – Not applicable

Section IV. Bidding Forms

Table of Forms

Bid Submission Form.....	12
Price Schedule:.....	13-22
Bid Security (Guarantee)	35
Manufacturer's Authorization	37

FORM OF BID
UVA WELLASSA UNIVERSITY
UWU/G/NCB/18/02

To: Chairman
Procurement Committee
Uva Wellassa University
Passara road,
Badulla

We, the undersigned, declare that:

Having examined the Instructions to Bidders and Conditions of Tender, Conditions of Contract, Schedule of Requirements, Schedule of Particulars and Bills of Quantities, I/ We the undersigned, offer to **Supply, Delivery, Installation & Commissioning of Laboratory Equipment for Department of Animal Science, Faculty of Animal Science and Export Agriculture Contract No: UWU/G/NCB/18/02** said Price Schedule amounting to Rupees and cents.....(Rs) only

I / We undertake to **Supply, Delivery, Installation & Commissioning of Laboratory Equipment for Department of Animal Science, Faculty of Animal Science and Export Agriculture** within the time stated in the tender documents, if our tender is accepted.

I / We agree to abide by this tender for period of 120 calendar days from the date fixed for receiving of Bids or any extended period and it shall remain binding upon us and may be accepted at any time before the expiration of that period.

Unless and until a formal Agreement is prepared and executed, this Tender, together with your written acceptance thereof, shall constitute a binding Contract between us.

I / We understand that, you are not bound to accept the lowest or any tender, you may receive.

This day of20..... in the capacity of..... duly authorized to sign Bids for and on behalf (indicate whether the Freehold Owner or Power of Attorney Holder) of (Blanks to be filled in BLOCK CAPITALS)

Signature.....

Duly authorized for signed on behalf of

(Name of the Bidder)

Address.....

.....

Date.....

Price Schedule

Supply, Delivery, Installation & Commissioning of Laboratory Equipment for Department of Animal Science, Faculty of Animal Science and Export Agriculture

Contract No: UWU/G/NCB/18/02

No	Items	QTY	Unit Price (excluding VAT)	Total Price (excluding VAT)	VAT 15%	Total Price including VAT
1	Stainless Steel Digital Smoker	1				
2	Digital Deep Fryer	1				
3	Patty Maker Attachment for Meat Grinder	1				
4	Heavy duty stainless steel brine injectors/Seasoning Injectors	2				
5	Bowl cutter	1				
6	Stainless Steel Meat Grinder and Sausage Stuffer	1				
7	Stainless Steel Meat Mixer	1				
8	Refrigerated centrifuge machine	1				
9	Distilled water unit	1				
10	Meat mincer+ stuffer (Home scale)	1				
11	Air fryer	1				
12	Microwave oven	1				
13	Meat cutting knives set	4 set				
14	Analytical Balance	1				
15	Moisture Analyzer	1				
16	Grain Grinder	1				
17	GPS	2				
18	Binocular Microscope	2				
19	Micro pipette (2µl-20 µl)	1				
20	Micro pipette (20µl-200 µl)	1				
21	Micro pipette (100µl-1000 µl)	2				
22	Micro pipette (1000µl-5000 µl)	1				
23	Vortex mixer	2				
24	Mini-Protein SDS PAGE gel electrophoresis unit with power pack	1				

Use separate price schedule for options

Total Price with VAT (in Words):

.....

Maintenance charges (as a percentage) after the warranty period (If any):

Vat Registration No:

Signature.....

Duly authorized for signed on behalf of
(Name of the Bidder)

Address.....

.....

Date.....

FORM OF BID SECURITY

[insert issuing agency's name, and address of issuing branch or office]

Beneficiary: Vice Chancellor, Uva Wellassa University, Passara road, Badulla

Date: ----- *[insert (by issuing agency) date]*

BID GUARANTEE No.: ----- *[insert (by issuing agency) number]*

We have been informed that -----
[name of the Bidder] (hereinafter called "the Bidder") has submitted to you its bid dated -----
[date] (hereinafter called "the Bid") for the execution of
..... *[insert name of Contract]* under Contract No. -----

Furthermore, we understand that, according to your conditions, Bids must be supported by a Bid Guarantee.

At the request of the Bidder, we ----- *[insert name of issuing agency]*
hereby irrevocably undertake to pay you any sum or sums not exceeding in total an amount of -----
----- *[insert amount in figures]* -----
----- *[insert amount in words]* upon receipt by us of your first demand
in writing accompanied by a written statement stating that the bidder is in breach of its obligation(s)
under the bid conditions, because the bidder:

- (a) has withdrawn its bid during the period of bid validity specified; or
- (b) does not accept the correction of errors in accordance with the Instructions to Bidders (hereinafter "the ITB") ; or
- (c) having been notified of the acceptance of its bid by the Employer during the period of bid validity, (i) fails or refuses to execute the Contract Form, if required, or (ii) fails or refuses to furnish the Performance Security, in accordance with the ITB.

This Guarantee shall expire: (a) if the Bidder is the successful bidder, upon our receipt of copies of the Contract signed by the Bidder and of the Performance Security issued to you by the Bidder; or (b) if the Bidder is not the successful bidder, upon the earlier of (i) the successful bidder furnishing the performance security, otherwise it will remain in force up to ----- *(insert date)*

Consequently, any demand for payment under this Guarantee must be received by us at the office on or before that date.

.....
[Signature of authorized representative(s)]



MANUFACTURER'S AUTHORIZATION

[The Bidder shall require the Manufacturer to fill in this Form in accordance with the instructions indicated. This letter of authorization should be on the letterhead of the Manufacturer and should be signed by a person with the proper authority to sign documents that are binding on the Manufacturer. The Bidder shall include it in its bid, if so indicated in the BDS.]

Date: [insert date (as day, month and year) of Bid Submission]

No.: [insert number of bidding process]

To: [insert complete name of Purchaser]

WHEREAS

We [insert complete name of Manufacturer], who are official manufacturers of [insert type of goods manufactured], having factories at [insert full address of Manufacturer's factories], do hereby authorize [insert complete name of Bidder] to submit a bid the purpose of which is to provide the following Goods, manufactured by us [insert name and or brief description of the Goods], and to subsequently negotiate and sign the Contract.

We hereby extend our full guarantee and warranty in accordance with Clause 27 of the Conditions of Contract, with respect to the Goods offered by the above firm.

Signed: [insert signature(s) of authorized representative(s) of the Manufacturer]

Name: [insert complete name(s) of authorized representative(s) of the Manufacturer]

Title: [insert title]

Duly authorized to sign this Authorization on behalf of: [insert complete name of Bidder]

Dated on _____ day of _____, _____ [insert date of signing]

Section V

Schedule of Requirements

1. List of Goods and Delivery Schedule

[The Purchaser shall fill in this table, with the exception of the column “Bidder’s offered Delivery date” to be filled by the Bidder]

No	Description of Goods	Qty	Final Destination as specified in BDS	Delivery Date 1		
				Earliest Delivery Date	Latest Delivery Date	Bidder’s offered Delivery date
1	As Listed in the Price Schedule		Uva Wellassa University	Within 4 Weeks of the Order	Within 4 Weeks of the Order	

* Destination of delivery: - Department of Animal Science
Faculty of Animal Science and Export Agriculture
Uva Wellassa University,
Passara Road,
Badulla.

2. Technical Specifications

The bidder shall follow the following technical requirement and other requirement

General Conditions



For equipment, Bidders should provide following details:

Country of origin catalogues, Mother company registration letter, possible date of supply, Mother company warranty period, After sales and service facility, Service agreement cost and free service period, Approximate value for main spare parts, Installation & operational manual/s, installation and demonstration should provide free of charge if this product is purchased, Local agent should have necessary tools to carry out complete service and repair.

Technical Specifications

Supply, Delivery, Installation & Commissioning of Laboratory Equipment for Department of Animal Science, Faculty of Animal Science and Export Agriculture - UWU/G/NCB/18/02

No	Item	Specifications	Bidders' Response	
1	Stainless Steel Digital Smoker	The interior and exterior of the smoker should be made with food grade stainless steel		
		Capacity: 30 lbs		
		Temperature range 100° – 250° F		
		The smoker should include following:		
		· 4 wire mesh shelves (food grade stainless steel) with approximately 1/4" square holes		
		· 4 wire mesh shelves (food grade stainless steel) with approximately 3/4" square holes		
		· 3 wood dowels to hang sausage		
		· Stainless steel sawdust pan		
		· Removable shelving brackets		
		· Digital control and internal temperature sensor built-in for precision and ease-of-use		
		· Drip collecting base directs drippings underneath smoker		
		· Raised heating element for cleaning clearance underneath the burner		
		· Smoke diffuser lowered to maximize meat capacity and is ventilated to disperse smoke more evenly		
		· Large rear casters and push/pull handle that allows easy mobility		
		· Opening for steam generating		
		The smoker should accommodate up to 12 shelves		
		Spacing between shelves: 1 3/4" minimum spacing		
		Outside dimensions: 17-19"D x 19-21"W x 48-50"H		
		Inside dimensions: 15-17"D x 16-18"W x 24-26"H (minimum) 34-36"H (maximum)		
		1,000 Watt, 220-240 Volt heating element		
Manufacturer product catalogs with requested information (highlighted) should be supplied				
After Sale Services should be provided by the technicians/engineers of the supplier				
Warranty: 2 years				
2	Digital Deep Fryer	1800-watt immersion style heating element which can be detached easily from the main unit.		
		Adjustable thermostat with signal light that indicates when oil is ready for frying		
		3 Oblong shaped mesh baskets with cool-touch handles (One large and two small mesh baskets)		
		Should be able to use two small baskets at a time or one big basket at a time.		
		Stainless steel, dual basket type deep fryer		
		Capacity: 4.5 L oil capacity		
		30 minute digital timer		
		Removable enamel-coated oil container		
		Power and ready LED indicator lights		
		3-5 pound food capacity		
		Warranty: 2 years		
		After Sale Services should be provided by the technicians/engineers of the supplier		

3	Patty Maker Attachment for Meat Grinder	It should be a universal patty making attachment.		
		It should include 5 attachment funnels that fits most #5, #8, #10/12, #20/22 and #32 meat grinders, attaches to some sausage stuffing machines as well.		
		· 2 1/8 " pter for #5 grinders		
		· 2 1/2" pter for #8 grinders		
		· 2 3/4" pter for #10/12 grinders		
		· 3 1/4" pter for #22 grinders		
		· 3 7/8" pter for #32 grinders		
		It should make up to 20 patties per minute		
Approx. weight of patties: 1/3 lb or 5 oz. each				
Patty size: 4- 4 1/2" diameter x 3/4" thick				
It is recommended to quote an item compatible with the stainless steel meat grinder listed in this tender.				
After Sale Services should be provided by the technicians/engineers of the supplier				
Warranty: 2 years				
4	Heavy duty stainless steel brine injectors/Seasoning Injectors	The injectors and needles should be made out of food grade stainless steel.		
		Needles should have threads and screws with durable silicone washers for easy assembling to Barrel		
		Should have 4 extra silicone O-rings (3 small silicone O-rings for needles and 1 large silicone O-ring for barrel)		
		Barrel capacity should be 2-3		
		Barrel length should be 6-7"		
		Barrel should have a easily disassembled cap		
		Zinc alloy barrel top with rust-proof and erosion resistant features		
		1 for chunky marinades (length of the needle: 5.5-6.0")		
		1 for bursting liquid marinades (length of the needle: 5.5-6.0")		
		Quick and easy disassembling feature		
		Should have 3 marinade needles with different lengths and diameters		
		1 for precision marinade (length of the needle: 4.2-4.5")		
		The needles should be ultra-sharp to puncture any meat with ease.		
		A storage pouch and 2 pieces of cleaning brushes		
Warranty: 2 years				
After Sale Services should be provided by the technicians/engineers of the supplier				
5	Bowl cutter	The bowl cutter should be constructed entirely of stainless steel with a strong and rigid cutting bowl.		
		It should come with 2-speed motor capable of cutting at 1420 and 2840 rpm which is thermally protected.		
		The bowl cutter should have a removable six-knife head and 6 stainless steel knives/blades.		
		It should contain the tool to fix and detach knives/blades.		
		It should include a digital mixture thermometer		
		Bowl and cutting head are all covered by a folding plastic anti-noise cover fitted with a safety switch.		

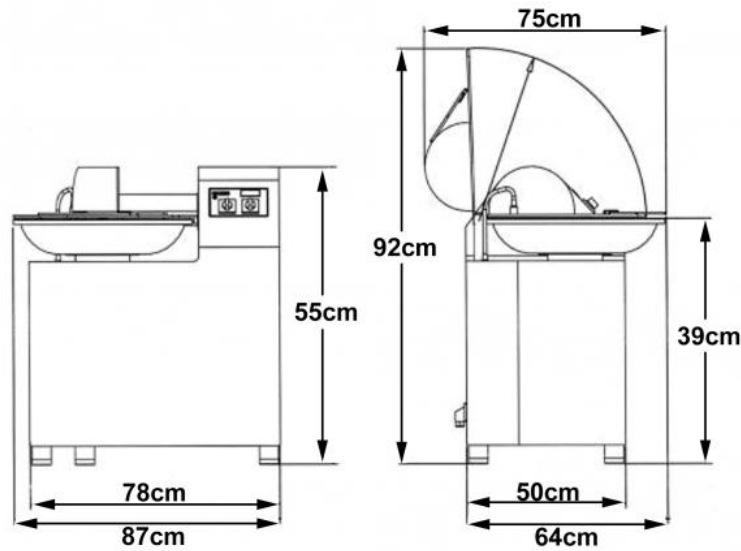

Sealed base.

Power 3ph 2.1/2.7 HP (1.6/2.0kW)

Bowl volume: 15 L

Meat bowl/mix Capacity: +/- 3-12 kg

Knife Speed: 1420/2840rpm

External Dimensions (W x D x H): 87 x 64 x 55 cm as given in the below diagram

Max. Weight range 160-175 kg

Manufacturer product catalogs with requested information (highlighted) should be supplied.

After Sale Services should be provided by the technicians/engineers of the supplier

Warranty: 2 years

6 Stainless Steel Meat Grinder and Sausage Stuffer

Meat Grinder and Sausage Stuffer should be constructed with food grade stainless steel and contain following;

Stainless steel cutting knife/blade

Two stainless steel grinding plates: coarse (7mm (3/10")) and medium (4.5mm (1/5"))

Three stuffing funnels with flange 20mm (4/5"), 30mm (1 1/5") & 40mm (1 3/5")

Stainless steel stuffing funnel 10mm (2/5")

Cyclone high speed stuffing auger

Stuffing star converts grinder into a sausage stuffer

All metal gear construction for optimum grinding performance

Powerful air-cooled motor, permanently lubricated (1100-1200 watt, 1.5 Horse Power, 120 volts-60Hz)

Equipped with a circuit breaker for safe use

Extra-large stainless steel hopper(15" width x 10" length x 2.5" height) equipped with safety guard

On/off switch with reverse functions

Sturdy handle for portability

Non-slip rubber feet keeps machine stable while in use

Capacity : should be able to grind up to 9 – 12 lbs of meat per minute

The grinder should be able to disassemble easily for clean-up

After Sale Services should be provided by the technicians/engineers of the supplier

Warranty: 2 years

7	Stainless Steel Meat Mixer	Mixer should have following features;	
		Constructed of polished stainless steel structure, tank exterior and paddle	
		Direct hand operation by crank	
		Removable stainless steel paddle for quick and easy discharge and cleaning	
		Transparent/clear food grade plastic lid	
		Rubber feet for stability	
		Tank capacity: 20-25 Lbs	
		Overall dimensions: 12-13"H x 9-10"W x 11-13"L	
		Tank dimensions: 11-12"H x 9-10"W x 11-13"L	
		After Sale Services should be provided by the technicians/engineers of the supplier	
Warranty: 2 years			
8	Refrigerated centrifuge machine	The controlled system of refrigerated centrifuge should be a Microprocessor with digital display.	
		Drive System should be direct, brushless induction low profile motor	
		The Centrifuge should have a feature to install and remove rotor without tool in less than 5 seconds with just a push of a button for quick and easy change of rotors for different applications.	
		It should have an auto-lock rotor locking system.	
		Temperature range should be from -10°C to +40°C with CFC free refrigeration system	
		The centrifuge must have a minimum of 6 direct access program keys.	
		It should have a timer of at least 9-10 hr and continuous operation	
		Acceleration/Deceleration rates shall be 9/10	
		Speed Accuracy should be 100 rpm or 100 x g	
		There should be a Pre-cooling function with direct button	
		Time Setting should be available with countdown from start	
		Highly visible, backlit display should be available for clear reading of parameters	
		Centrifugation chamber should be stainless steel	
		Speed Setting must be through Scrolling arrow keys	
		Centrifuge should have advanced imbalance technology that pts for specific rotors	
		Sound level should be less than 63 dB with swinging bucket rotor at top speed	
		Instrument should be easily toggle between RCF and RPM	
		It should have a glove- and detergent-friendly panel and a power save feature that turns off display when not in use	
		The centrifuge must be UL listed, CSA certified, CE marked, IVD compliant, Certified Biosafety, RoHS compliant, WEEE compliant	
		<u>Details of Rotor and other accessories</u>	
		· Swing out bucket rotor	
		· Rotor capacity should be 4 x 750 ml	
		· Rotor speed: 4700-4800 rpm (max. speed)	
		· Four (04) round buckets	
		· Four (04) click sealing type biocontainment lids for round buckets.	
		· Four (04) replacement O-rings for lids	
		· Four (04) ptors to accommodate 28-32 Nos. of 50-ml conical tubes (7-8 tubes/ptor)	
		· Four (04) ptors to accommodate 56-60 Nos. of 15-ml conical tubes (14-15 tubes/ptor)	
		Manufacturer product catalogs with requested information (highlighted) should be supplied	
		Manufacturer authorization for the bidder to represent the given brand	
User reference list should be attached			
Bidder should have good aftersales facility with trained technicians/engineers and parts available locally to carry out any service/repair immediately			
Warranty: 2 years			

9	Distilled water unit	Distilled water unit should have following features;	
		· It should supply at least 4 L/ hour	
		· Automatic operation	
		· Heating element should be made of stainless steel	
		· Good distillate quality with conductivity of approx. 2.3 $\mu\text{s} / \text{cm}$ at 25 °C	
		· Built-in distillate storage tank with a minimum capacity of 8 L	
		· Storage tank for distillate accepts double the hourly capacity of the unit.	
		Material: stainless steel	
		· Condenser (cooling coil) in the storage tank should be made of stainless steel and easily exchangeable	
		· An electronic level switch to switch the still off when the storage tank is full and restarts it automatically when distillate is withdrawn	
		· Impurity detector switches to off the unit in case of high degree impurities in the evaporator	
		· Distillate withdrawal through the drain cock on the front of the unit	
		· The drain cock should be able to open in either continuous or touch position	
		· Main switch and pilot lamps should be on the front of the unit	
		· Degassing of carbon dioxide through vent in the top	
· Double-walled made of electrolytically galvanized sheet steel, electrostatically powder-coated with epoxy resin			
· Cooling Water consumption shall be not higher than 50 L/h			
· Power consumption shall be not higher than 3 KW			
· System shall be able to work on single phase power supply			
Manufacturer product catalogs with requested information (highlighted) should be supplied			
After Sale Services should be provided by the technicians/engineers of the supplier			
Warranty: 2 years			
10	Meat mincer+ stuffer (Home scale)	The home scale mincer should have following features;	
		· Performance: 2.5-3.0 kg/ min mincing	
		· 2 stainless steel screens/discs: medium (5 mm) and coarse (8 mm)	
		· Metal tray with a dust cover	
		· Knife should be impossible to assemble incorrectly on the feeding screw	
		· 2 sausage horns (12 mm diameter and 22 mm diameter)	
		· Accessory storage tray	
		· Kebber maker	
		· Cookie making accessory	
		· Two-sided cleaning tool	
		· Voltage : 220-240 V	
		· Frequency: 50 Hz	
		· Speed: 1+ Reverse	
		· Blocked power 2000 W & Nominal power 600 W	
		After Sale Services should be provided by the technicians of the supplier	
Warranty: 2 years			
11	Air fryer	Air fryer should have ability to fry, grill, roast and bake.	
		· Power: 1400 W	
		· Voltage: 220-240 V	
		· Automatic shut-off	
		· Cool wall exterior	
		· Temperature control & Time control	
		· Ready signal	
		· Recipe book & App	
		· Non-slip feet	
		· Cooking basket should have a mesh bottom with non-stick coating which easily detaches for quick cleaning	
		After Sale Services should be provided by the engineers of the supplier	
Warranty: 1-2 years			

12	Microwave oven	Charcoal Convection type microwave oven should have following features;	
		· Capacity: 30-32 L	
		· Stainless steel cavity	
		· Control type: glass touch	
		· 5 microwave power levels	
		· Microwave frequency (MHz): 2450	
		· Watts Microwave (output): 900	
		· Watts Grill (input): 1250	
		· Watts Convection (input): 2400	
		· Watts Combination (input): 2400	
		· Variety of cooking features including followings;	
		- Fermentation	
		- Keep warm option	
		- Steam clean option	
		- Custom cook option	
		- Quick menu option	
		- Two stage cooking option	
		- Quick start option	
		- Combination cooking option	
		- Fast cook option	
- Quick defrost option			
- Auto cook options			
- Auto defrost options			
After Sale Services should be provided by the engineers of the supplier			
Warranty: 1-2 years			
13	Meat cutting knives set	12 piece knife set with a storage briefcase.	
		· 9" round sharpening steel	
		· 7" cleaver	
		· 6" meat fork	
		· 6" straight boning knife	
		· 3 1/2" paring knife	
		· 5" paring knife	
		· 8 1/2" serrated slicer knife	
		· 9 1/2" cook knife	
		· 7 1/2" carving slicer	
		· 9 1/2" carving slicer	
		· 3" scissors	
		· 5" utility kitchen shears.	
		All knives should have durable stainless steel blades	
All knives should have riveted handles			
Warranty: 2 years			
14	Analytical Balance	Capacity – 220g; Reblity [d] – 0.1mg	
		Repeatability – 0.1mg	
		Stabilization time – 3.0 sec	
		Pan size 80 mm diameter	
		Calibration – Internal & External	
		Measuring system : Tuning – fork frequency system	
		Tare – Full weighing range	
		Display – Back- lit LCD display; Dry cell battery pack; One year warranty	

15	Moisture Analyzer	Application- Measurement of Moisture by evaporation loss Range of Products- Grain, Processed Food, Copra, Animal feed ingredients, Formulated feed pellets etc.	
		Measurement range 0 to 100% (Wet base solids) 0-500% (dry base)	
		Operating modes- Both timed and auto	
		Sample weight 1g to 100 g; Temperature range 30 ⁰ C to 200 ⁰ C	
		Power consumption 750-1000W	
		Sample Pan- Stainless steel , diameter 110 mm or higher Display	
		Visual alarm for Drying ;Power 220V 50-60 Hz	
		Warranty – Minimum 2 Years	
		Spare parts availability- 10 Years	
		Reblity balance: 0.005 g, Measurement mode: Automatic operation mode, Timed operation mode	
		Items included: Sample pan×2, sample pan handler, windshield, sample panbase, spoon and spatula set, sample aluminum sheet×10, operation manual	
16	Grain Grinder	Grain Mill with stand mixer attachment	
		Six grind levels	
		Grind worm	
		Bench top	
		Adjustment knob-Large knob adjusts the fineness of the grind with confirming clicks for positive precision settings	
		Enduring Design-Die-cast metal construction, Grain mill body	
		Easy to clean	
		Designed to mill all type of grains such as wheat, corn, rye oats, rice, buckwheat, barley and millet	
		Capacity: maximum 1 kg	
One year warranty			
17	GPS	Should be able to track satellite signal even under thin forest canopy, Pixel dimension: Approximately 160 x 240 pixels, Physical dimension: Approximately 6.1 x 16.0 x 3.6 cm or equivalent, Display size: Approximately 3.6 x 5.5 cm or equivalent, High-sensitivity, Color screen : should be able to read the screen even in high sunlight condition, should be able to share data wirelessly, light weight (Approximately > 250 g) and with a built-in worldwide map, 2 AA batteries or rechargeable batteries, should be able to store 4000 or above waypoints/locations	
		At least six months warranty period	
		Accessories: Casing, Download Cable, Software (for data downloading)	
18	Binocular Microscope	Availability of an ergonomically designed Binocular tube with 360 degrees rotatable facility.	
		Locking pin should available for the safety binocular head.	
		Inter pupillary distance of the binocular heads should be adjustable between 48-75mm.	
		The Eye pieces should be fixed by a screw in the binocular tube to prevent damages or loss when moving the microscope.	
		The binocular Eye-pieces should have facility to adjust the Eye-point height adjustment for many student's comfort usage.	
		Eye piece with 10X magnification, field of view 20mm with front soft rubber cup with dioptry adjustment facility.	
		The microscope should be offered with Plan-Achromat Objectives and which should be suitable for bright field observation	

		Quadruple inward facing revolving nose piece with availability of plan 4X , 10X , 40X, 100X oil immersion objectives.	
		All the optics should be Anti-Fungal coated and should be proved by the Original literature. (Should mention both Eye pieces and Objectives)	
		Should be provided with the Abbe type condenser with height adjustment facility.	
		Availability of right hand side Stage clip with the Wire driven mechanism.	
		The illumination should be low power consumed LED illumination system.	
		Coarse focusing movement range should be 15mm and High sensitivity fine focusing knob	
		Minimum grtion per stroke should be 2.5 µm in the Fine focusing knob	
		There should be focus lock to prevent objectives and specimen from any damage	
		Stage movement range should be within 76mm (x - direction) and 30mm (y - direction)	
		Torque adjustment knob should be incorporated to adjust the tension of the coarse focusing knobs.	
		Supplier should provide Manufacturer's Authorization letter for sale from the same manufacturer to prove the Sole Authorized distribution in Sri Lanka.	
		The unit price for all spare parts and accessories shall be quoted separately.	
		At least eight year guarantee letter from the manufacturer on the availability of spare parts shall be supplied.	
		At least 10 years of experience in providing and handling microscopes in similar capacity; documentary evidences should be provided.	
		Letter of Manufacture Authorization	
		Warranty period two years	
		Prefer Olympus or equivalent.	
19	Micro pipette (2µl-20 µl)	Accuracy for volume 2ul± 0.5 and 20ul ± 1.0	
		Digital Volume setting , UV resistant Micro pipette	
		Fully autoclavable at 121 ⁰ C for 20 minutes	
		Plunger materials should be non-corrosive ceramic.	
		Ejector must be without metal parts to prevent corrosion and damaging to the glasses. chemical resistant, corrosion proof and abrasive	
		Easy single hand lock lever, which give the lock mechanism.	
		Pipette should be non-greasing type pipette	
		High accuracy ±0.7-±0.8	
		High Precision	
		Please indicate major consuming spare parts prices	
		Please mention the after sales facilities / Calibration services available	
		Compatible for universal tip sizes	
		Spare parts should be available for Next 10 Years	
		All the specifications required should be mentioned on the Original literatures.	
		Minimum warranty period – 3 years	
		Please attach the list of user references	
		Nichipet or equivalent	

20	Micro pipette (20µl-200 µl)	Volume(20 µl – Accuracy ±1.0,100 µl – Accuracy ±0.8,200 µl – Accuracy ±0.8)	
		Digital Volume setting , UV resistant Micro pipette	
		Fully autoclavable at 121°C for 20 minutes	
		Plunger materials should be non-corrosive ceramic.	
		Ejector must be without metal parts to prevent corrosion and damaging to the glasses. chemical resistant, corrosion proof and abrasive	
		Easy single hand lock lever, which give the lock mechanism.	
		Pipette should be non-greasing type pipette	
		High accuracy ±0.7-±0.8 & High Precision	
		Please indicate major consuming spare parts prices	
		Please mention the after sales facilities / Calibration services available	
		Compatible for universal tip sizes	
		Spare parts should be available for Next 10 Years	
		All the specifications required should be mentioned on the Original literatures.	
		Minimum warranty period – 3 years	
Please attach the list of user references			
Nichipet or equivalent			
21	Micro pipette (100µl-1000 µl)	Volume(100 µl – Accuracy ±1.0, 500 µl- Accuracy ±8.0, 1000 µl Accuracy ±0.7,)	
		Digital Volume setting , UV resistant Micro pipette	
		Fully autoclavable at 121°C for 20 minutes	
		Plunger materials should be non-corrosive ceramic.	
		Ejector must be without metal parts to prevent corrosion and damaging to the glasses. chemical resistant, corrosion proof and abrasive	
		Easy single hand lock lever, which give the lock mechanism.	
		Pipette should be non-greasing type pipette	
		High accuracy ±0.7-±0.8 & High Precision	
		Please indicate major consuming spare parts prices	
		Please mention the after sales facilities / Calibration services available	
		Compatible for universal tip sizes	
		Spare parts should be available for Next 10 Years	
		All the specifications required should be mentioned on the Original literatures.	
		Minimum warranty period – 3 years	
Please attach the list of user references			
Nichipet or equivalent			
22	Micro pipette (1000µl-5000 µl)	Volume(1000 µl – Accuracy ±1.0,2500 µl –Accuracy ±0.8,5000 µl–Accuracy ±0.6)	
		Digital Volume setting , UV resistant Micro pipette	
		Fully autoclavable at 121°C for 20 minutes	
		Plunger materials should be non-corrosive ceramic.	
		Ejector must be without metal parts to prevent corrosion and damaging to the glasses. chemical resistant, corrosion proof and abrasive	
		Easy single hand lock lever, which give the lock mechanism.	
		Pipette should be non-greasing type pipette	
		High accuracy & High Precision	
		Please indicate major consuming spare parts prices	
		Please mention the after sales facilities / Calibration services available	
		Compatible for universal tip sizes	
		Spare parts should be available for Next 10 Years	
		All the specifications required should be mentioned on the Original literatures.	
		Minimum warranty period – 3 years	
Please attach the list of user references			
Nichipet or equivalent			

23	Vortex mixer	Digital vortex mixer, with adjustable stirring speed	
		- Two operating modes- IR sensor and continuous	
		- IR (Infra-red) sensor mode- Infra red detects the presence of test tube, automatically	
		- Speed regulation up to 3000 rpm	
		- Suitable for work in the laminar flow cabinet	
		- simple operating, digital display-	
		- Speed accuracy – 5%	
		- Timer – which helps user to set the operating time	
		- Power supply 220 - 240VAC, 50Hz	
		- two additional Plat forms for multiple tubes and micro plates should come with the instrument	
- Warranty at least 01 year			
24	Mini-Protein SDS PAGE gel electrophoresis unit with power pack	1-4 gel mounting ability	
		Precast gels	
		Power unit	
		Total buffer volume (4gels 1000ml)	
		Should include Lid with power cables, tank, Electrode assembly, companion running module, mini trans-blot module	
		With 10 well (30 ul) combs	
		With 15 well (15 ul) combs	
		10 sets of glass plates	
		02 casting stands	
		4 casting frames with stand and rubber pads	
>02 year warranty			

Section VII

Contract Data

The following Contract Data shall supplement and / or amend the Conditions of Contract (CC). Whenever there is a conflict, the provisions herein shall prevail over those in the CC.

CC 1.1(i)	The Purchaser is: Uva Wellassa University
CC 1.1 (m)	The Project Site(s)/Final Destination(s) is/are: Uva Wellassa University, Passara Road, Badulla.
CC 8.1	For notices, the Purchaser's address shall be: Deputy Bursar Uva Wellassa University, Passara Road, Badulla. 055-2226475/ 055-2226633
CC 11	Goods shall be supplies in compliance with the quality and the specification given.
CC 15.1	CC 15.1—The method and conditions of payment to be made to the Supplier under this Contract shall be as follows: For Goods offered within Sri Lanka Payment shall be made in Sri Lankan Rupees within thirty (30) days of presentation of claim supported by a certificate from the Purchaser declaring that the Goods have been delivered and that all other contracted Services have been performed. a) No Advance payment applicable for this contract b) Up to a maximum of ninety (90) percentage of the Contract Price, shall be paid on receipt of the Goods and confirm by the evaluation committee. c) Ten (10) percentage of the Contract price will be hold as Retention for a period of 12 months from the date of commissioning of equipments. d) The Retention shall be paid on completion of Twelve (12) months. During that period supplier shall correct all defects and confirmed by the purchase or his agent.
CC 17.1	A Performance Security – 10% Performance security may be in any of the following way (a) A Bank guarantee issued by a reputed bank operated in Sri Lanka. (b) Cash deposit at the Shroff Counter of the University
CC 26.1	The liquidated damage (Late Delivery) shall be: 1% from the contract sum, per week.
CC 26.1	The maximum amount of liquidated damages shall be: 10 % from the contract sum.
CC 27.3	The warranty shall remain valid for a period of time specified with the specifications.
CC 27.6	The supplier shall remedy the defects within 3 Months from the date of information by the purchaser.